

Ecooustic® Edge

—
An elegant acoustic modular tile designed
by Adam Goodrum + Patryk Koca



INSTYLE

Ecoustic® Edge Tile by Adam Goodrum + Patryk Koca

Front View

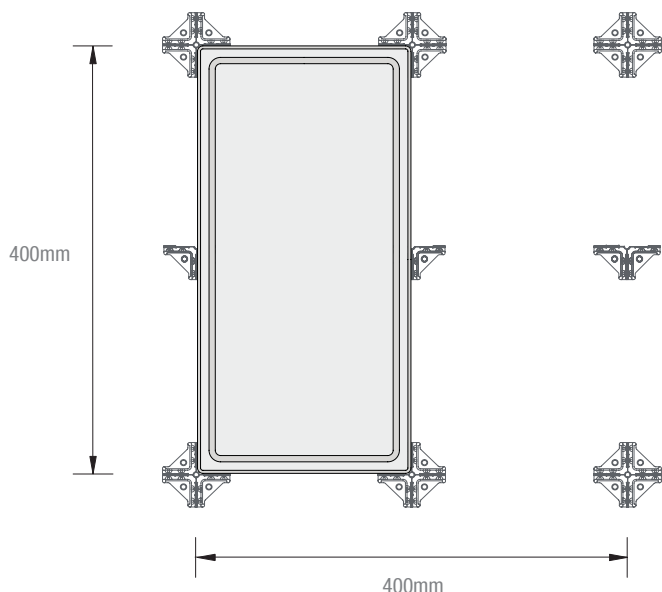

Side View

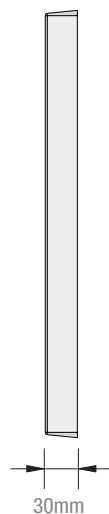

PRODUCT Ecoustic® Edge Tile

DESCRIPTION Ecoustic® Edge is a sophisticated acoustic modular tile inspired by simple geometry, designed by Adam Goodrum + Patryk Koca

DIMENSIONS 200mm (w) x 400mm (h) x 30mm (d)

ACOUSTIC NRC 0.75 / α_w 0.6 M,H / SAA 0.77*
*Tested with an Ecoustic® Infill
Excellent absorption NRC 1 (500 Hz) for critical speech range frequencies

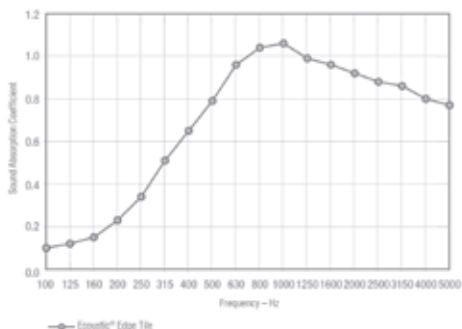

FIRE TEST AS/NZS 1530.3

Ignitability	9
Spread of Flame	0
Heat Evolved	3
Smoke Developed	6

GB8624-2012 Grade B1

APPLICATION wall tiles

ORIGIN Designed and made in Australia

FINALIST AWARDS Interiors & Sources 2019 Readers' Choice Awards
Interior Design's Best of Year 2019 Award

Please contact your representative for CAD drawings

BENEFITS

Lightweight, Easy to Handle + Install: Position the 4-way clips using the template provided, then simply press the tile into place. The design can be easily extended at a later stage.

Designed for the Environment

- Based on low energy manufacturing
- 100% polyester (up to 23% PC + PI recycled content)
- Designed for disassembly + recyclable
- Low-VOC, EPD + Greentag Level A Certified

Warranty: A 12 month warranty is provided against manufacturing defects. Internal installation only, outdoor use will void any warranty.

Building Rating Systems: Edge will contribute the following points for Green Star, LEED + WELL building standards.

Criteria	Green Star	LEED	WELL
Recycled Content	✓	✓	NA
Low VOC	✓	✓	✓
Recycling Program	✓	✓	NA
EPD	✓	✓	NA
Third Party Greentag Level A Certification	✓	✓	✓
Toxic Material Reduction	NA	NA	✓

HOW TO SPECIFY

DESIGN	Ecoustic® Edge Tile
COLOUR	Select from Ecoustic® Felt colours
ECOUSTIC® INFILL	Optional extra - order separately

Tile Components

Screws

Flat-head c/sunk 25mm 10g
 [2 per 4-way clip]
 Not supplied

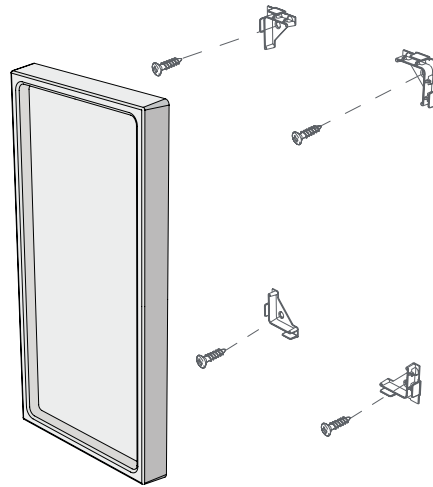

Ecoustic® Edge Tile

100% polyester (up to 23% recycled content)
 16 tiles per box in a single colour



4 way clip

Clear ABS
 16 + 1 spare 4-way clips are supplied with each box
 Single clip template is included in each box

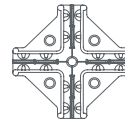

Complete

Use a complete clip for each junction of 4 tiles

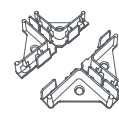

Half

Break a clip in half for each straight edge 2 tile joins

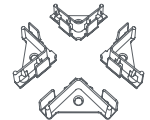

Quarter

Break clip into quarters for each single tile corner

Example 1600mm x 1600mm Clip Layout

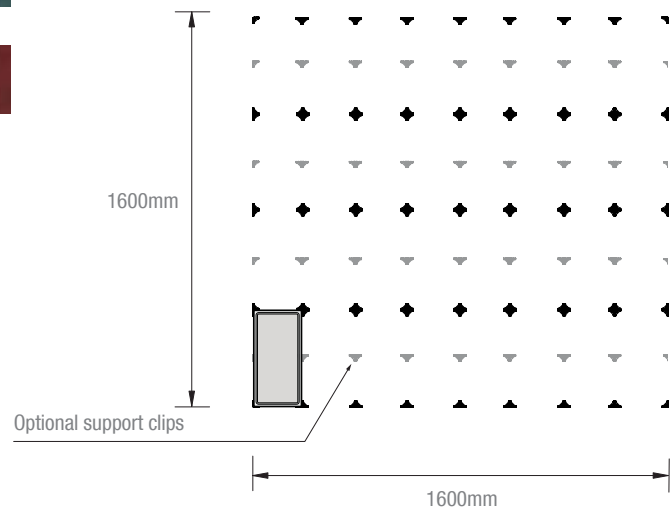

Product may vary in colour due to the nature of the media
 Please refer to website for current colour range

Variation in fibre mix and colour is an inherent feature of this product and variation from batch to batch may occur