



# Installation Guide

Acoustic Wall Panels

---

November 2021

# Preface

---

## Wall Preparation

Before beginning the installation process, ensure that the surface is clean (free of any dust, flaking paint, loose debris or grime), structurally sound, dry and free of imperfections.

Wear gloves at all times throughout the installation process. When cutting and fitting panels to fit the space, consider which areas of the surface will contain the cut portions and try to apply the products as symmetrically as possible. It may help to measure and mark the space beforehand.

## Printed Panels

Ensure that all Acoufelt QuietPrint™ Printed Panels are installed at the correct orientation as provided by the Acoufelt print and installation plan. This is to avoid any variation in pattern that may impact the overall look of the finished installation.

**DISCLAIMER:** Acoufelt strives to fulfil the needs of their customers by producing the highest quality felt products. However due to the fine, fibrous and textural nature of the product, slight visual imperfections may be seen when viewing the product from less than 1 to 1.5 meters. These slight visual imperfections however, are within normal industry manufacturing tolerances. When installing QuietPrint™ Printed Panels, we recommend that you align the panels to their closest match at eye level, and allow for +/- 5mm Alignment Tolerance.



# Adhesive Method

## Tools & materials required:

- Clean gloves
- Utility knife
- Straight edge
- Measuring tape
- Ladder/scaffolding
- Caulking gun
- J-Roller
- Construction adhesive
- Spray adhesive

## Preparation

1. Wear clean white gloves throughout the installation process. Use matching caulk to fill in any unwanted cracks in joints or between panels and ceilings.
2. After preparing the surface for installation, dry fit (without adhesive) the panels. Measure the panels against the surface and ensure they are straight and line up. If required, use the utility knife and the straight edge to accurately cut the panels to the appropriate dimensions.
3. Trim off an excess material around joins, pipes, vents or lighting.

## Applying construction adhesive

- Using the caulking gun and construction adhesive, apply the adhesive around the inner edge of the ceiling panel. To avoid adhesive flowing through the joins when the panels are installed, apply the adhesive two finger widths away from the corner/join, then apply adhesive in a zig zag pattern across the centre of the panel, (as shown in fig. a).

Fig. a

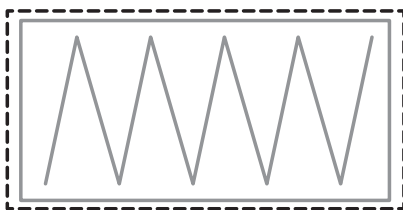

- Panel installation area
- Construction adhesive

## Applying spray adhesive

- Apply the spray adhesive around the inner edge of the panel, 50-100mm widths away from the panel perimeter (as shown in fig. b). Wait 5-10 minutes for the adhesive to become tacky before installing the panels.

## Installation

4. Keeping the panel as straight as possible, press the underside of the panel onto the ceiling surface. Apply pressure to panels when mounting to ensure the seams are tight, otherwise we recommend leaving a reveal between panels.
5. Apply even pressure with the roller and firmly press all areas of the panel to the surface. If required, hold the panels in place for a few minutes using poles or scaffolding.
6. Wipe away any leaked or excess adhesive from the panel before beginning the adjoining panel. Avoid any adhesive making contact with face of the panel.
7. Trim off any excess material around joins, pipes, sockets etc.

Fig. b

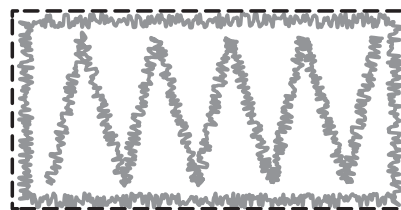

- Panel installation area
- ~~~~~ Spray adhesive

# Pot Magnet Method

## Tools Required (not provided)

- Clean gloves
- Straight edge
- Measuring tape
- Ladder
- Construction adhesive (we recommend SOUDAL Fix All High Tack)
- Screws 9g x length determined by substrate material when attaching magnet to wall
- Utility Knife

**Note: screws are not supplied**

## Accessories (provided)

- 6 metal plates (for attaching to panel)
- 9 pot magnets
- 3 L-plate

## Pot Magnet Method Steps

1. Prepare the wall surface for installation, use matching caulk to fill in any unwanted cracks in joints.
2. Wear clean white gloves throughout the installation process.
3. Use a straight edge and measuring tape to mark the wall for attaching the 9 pot magnets in a configuration of 3 along top, middle and bottom of the panel. Note: the placement of magnets on the wall will need to line up with the metal plates on the back of the panel.
4. Mark out the corresponding attachments for metal plates on the panel in the same configuration (3 along top, middle and bottom of the panel). Apply the same adhesive to the L metal plate and fix onto the lower position of the wall. Ensure that the L metal mounts are aligned horizontally to maintain the correct vertical alignment of the panel.
5. Screw the 9 pot magnets to the wall using appropriate 6g screws for substrate. Ensure that the bottom L metal plate captures the pot magnet. This will ensure that the panel doesn't slip down during installation.
6. Glue the metal plates to the back of the panel in marked locations. The glue will need to cure for approximately 12 hours before attaching panel to the wall. A longer curing time may be required in colder conditions.
7. Once the glue has cured, install by lining up the metal plates on the back of the panel with the pot magnets on the wall, and attaching into place.

Note: to prevent the panel from slipping down a wall where it is not directly to the floor or a skirting, we recommend supporting the panel by using 3 x L plate on the top 3 locations of the adjacent pot magnet as per drawing.

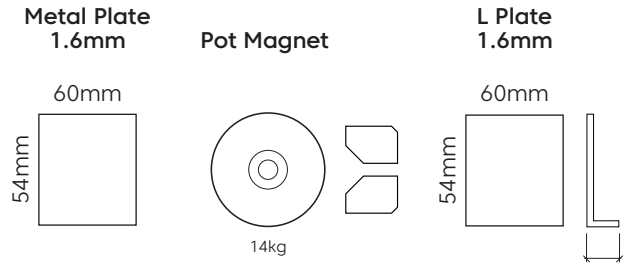

Wall Pot Magnet Install Metal Plate

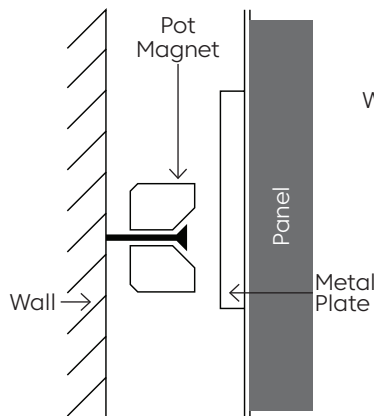

Wall Pot Magnet Install L Plate + Metal Plate

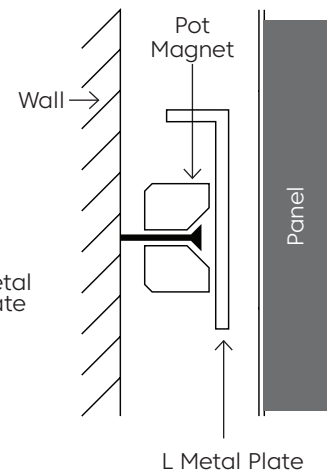

L Plate Wall+ Metal Plate Configuration

○ L Metal Plate    × Metal Plate



# Z-Clip Method

## Tools Required (not provided)

- Clean gloves
- Straight edge
- Measuring tape
- Ladder
- Construction adhesive (we recommend SOUDAL Fix All High Tack)
- Screws 6g x length determined by substrate material when attaching magnet to wall
- Utility Knife

**Note:** screws are not supplied

## Accessories (provided)

- 6 metal plates (for attaching to panel)
- 9 pot magnets
- 3 L-channels

## Steps

1. Determine the location and layout of where the panel(s) will be mounted to the wall (fig. a). Ensure brackets line up with the z-clips and use construction adhesive to adhere the z-clips both to the wall and behind the panels (fig. b).
2. Mirror mounting locations from panels onto the wall to line up with the z-clips on the back of the panels (fig.c).

fig. a

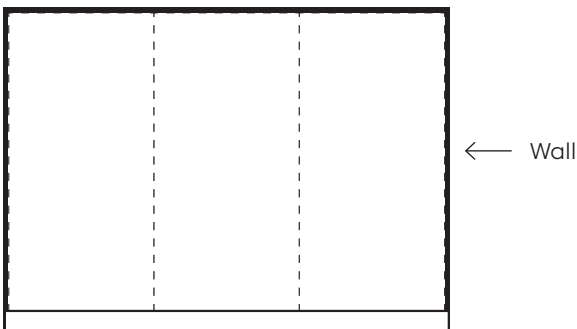

fig. c

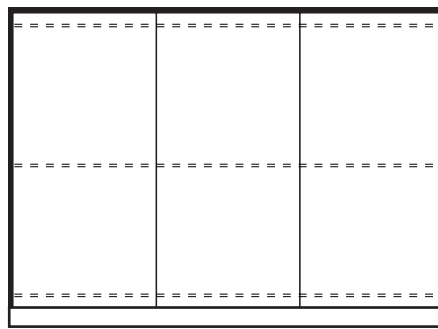
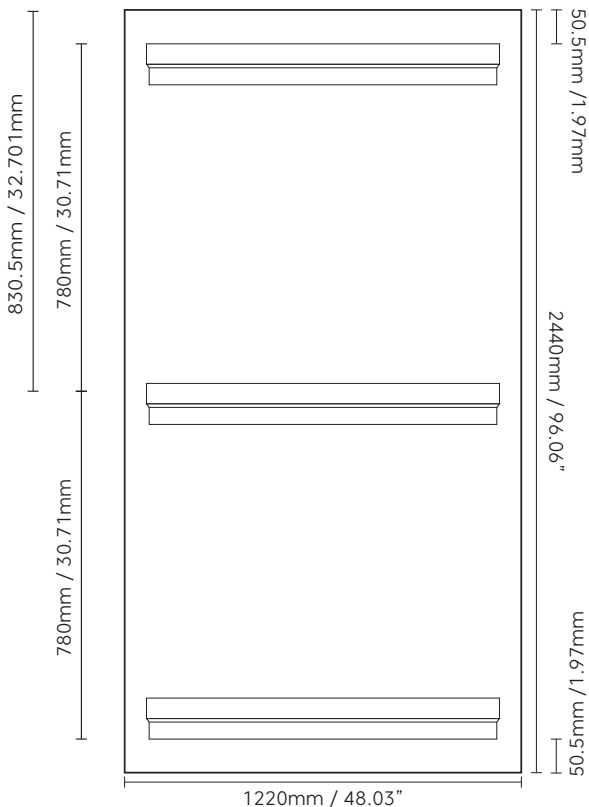
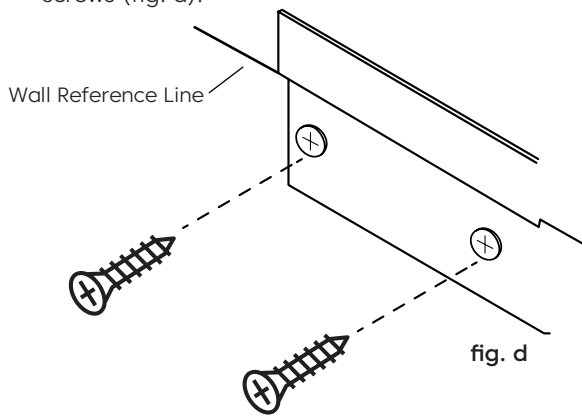

fig. b



# Z-Clip Method (continued)

1. Secure the z-clips to the wall with appropriate screws (fig. d).



2. Slide panel z-clip onto the wall z-clip. Ensure panels will mount plumb and level. Repeat these steps for multiple panels (fig. d). Please ensure the panels are well butted together at joints to allow for pattern matching.

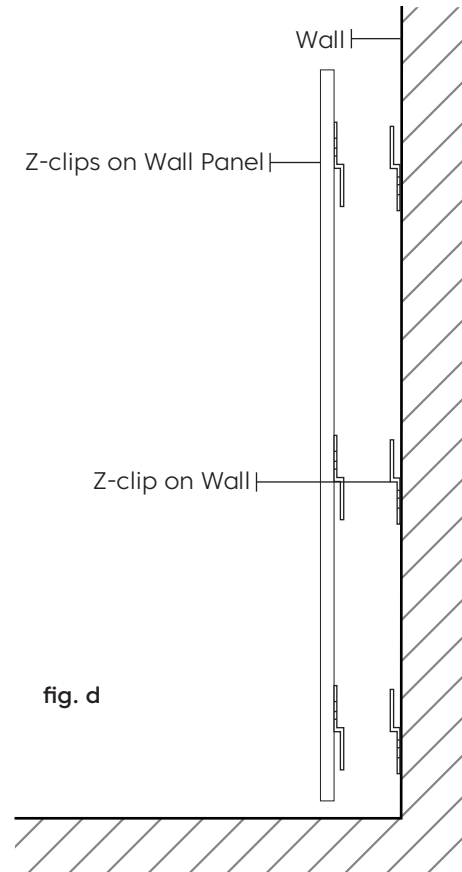

# Corners & Bends

## Tools & materials required:

- Utility knife/cutting tool
- Measuring tape/ruler

## Steps:

1. Measure the corner of the wall/column and ensure the panels will fit seamlessly. Consider the extra panel surface area needed when bending around a corner.
2. Identify and mark the centre line for the groove on the back of the panel to align with the corner edge of wall/column. Measure parallel lines equal distance on either side of this centre line to indicate where to cut the v-shaped groove (see figure 1). The appropriate size of the groove varies depending on the panel thickness. For 12mm acoustic panels, a total width of 2cm/0.78" (1cm/0.39" either side of centre) is suitable.
3. On the edge of the panel, mark the 'v', with the tip 2mm/0.08" from the front surface of the panel (see figure 2).
4. Use a utility knife or a cutting tool to gently cut the v-groove and remove material (see figure 3). Gradually expand the 'v' if required.
5. Bend panel and fix to wall with desired mounting method (see figure 4).

fig 1

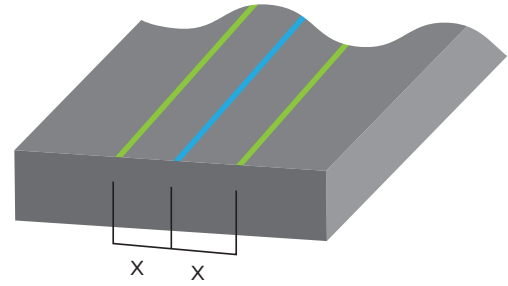

fig 2

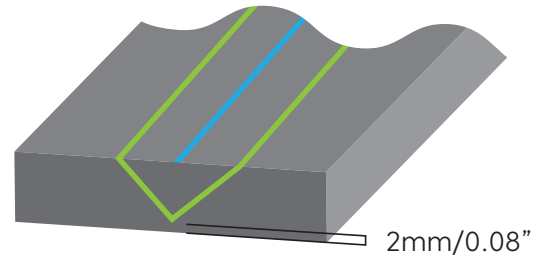

fig 3

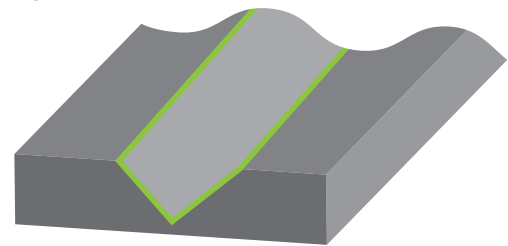
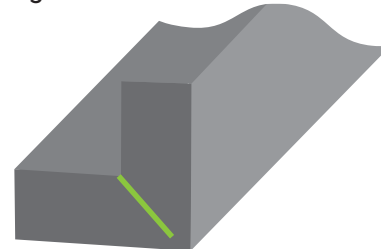

fig 4



# Inside Corners

## Tools & materials required:

- Stanley knife/cutting tool
- Measuring tape/straight edge

## Steps - Printed Panels (see fig. a):

1. Account for the 12mm / 1/2" panel thickness gap on each wall.
2. Cut the material using a straight edge and stanley knife.
3. Make sure to work from the corner outwards so the design butts perfectly.

## Steps - Full Color Panels (see fig. b):

1. Account for the 12mm / 1/2" panel thickness gap on each wall.
2. Cut the material using a straight edge and stanley knife.
3. Make sure to work from the corner outwards so the panels fit perfectly.

fig a

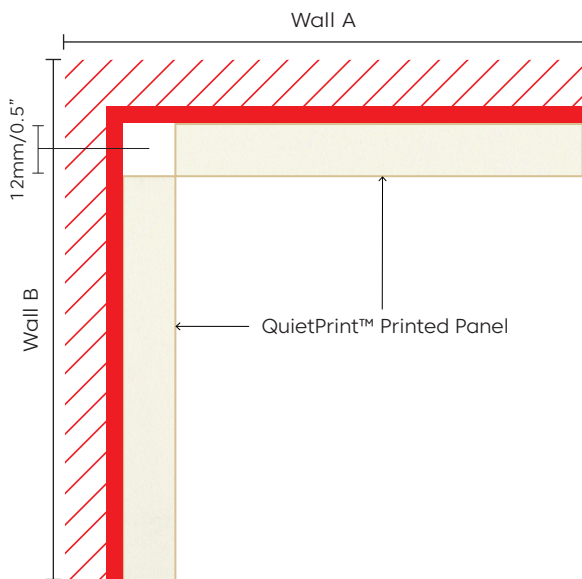
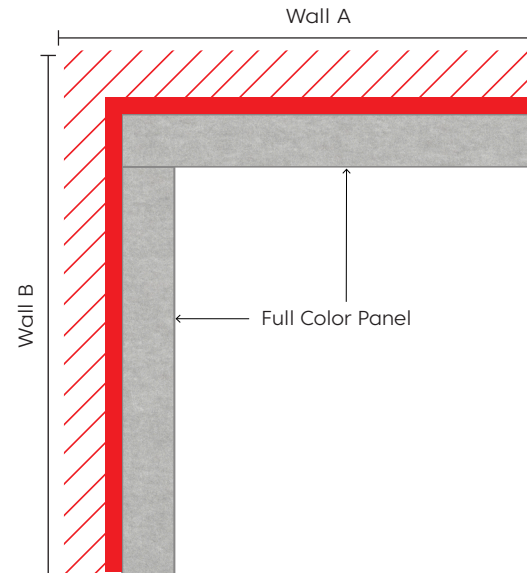

fig b





acoufelt  
making quiet

[acoufelt.com](http://acoufelt.com)