



ACOUSTIC TILES

WOVENIMAGE.COM





WOVEN IMAGE®

ACOUSTIC TILES

DESIGN FREEDOM WITH ACOUSTIC PERFORMANCE

Decorative acoustic tiles are the perfect product range for designers looking to achieve acoustic function with a quality design.

The portfolio boasts an extensive solid colour palette as well as printed, precision cut and 3D formed tiles, providing an endless stream of design configurations.

COMMERCIAL INTERIOR APPLICATIONS

Whether you're looking for floor to ceiling coverage or to create smaller design features, acoustic tiles are a stylish way to control noise in interior spaces including:

- Open-plan offices, meeting rooms and collaborative workspace
- Cafés and restaurants
- Lobby's and public spaces
- Classrooms and music rooms

EASY INSTALLATION

Our acoustic tiles are lightweight and easy to install. Designs pattern match without the need for trimming. Tiles are either mounted using adhesive or, with our 3D tile range, installed using a sophisticated clip system.

ENVIRONMENTALLY CONSCIOUS

Most tiles in the collection are made from EchoPanel®, which achieves Global GreenTag™ certification (Green Rate: Level A)¹.

EchoPanel® is made using 60% post-consumer PET from single-use bottles that would otherwise end up in landfill or our oceans.

Impressively, in 2018/19, Woven Image diverted in excess of 624 tonnes of PET plastic from landfill. This equates to over 31 million waste bottles.

To date, over 230 million 600ml PET bottles have been repurposed to produce EchoPanel® products.

For more information, full product specifications or to request a sample, please contact your local Woven Image representative, call +61 1800 888 650 or visit www.wovenimage.com

THE ECHOPANEL® PRODUCTION PROCESS

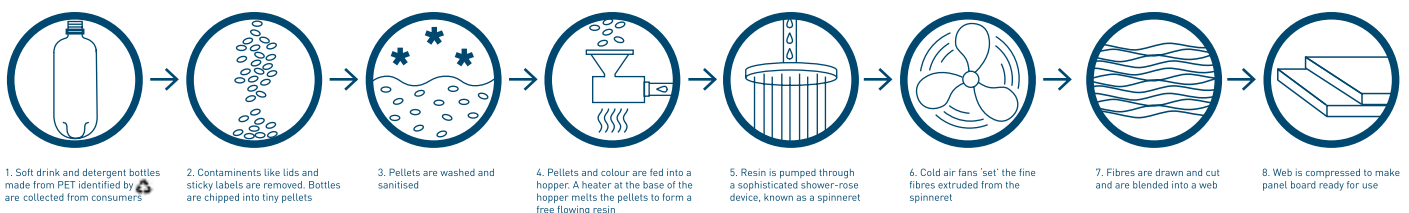

¹Visit Wovenimage.com for further information, or a copy of our full Environmental Product Declaration





Mura in colourway #349

EchoPanel® and Mura™ are available in a comprehensive range of neutral, mid tone and vibrant colours. Colours shown are for reference only, please contact your local Woven Image representative for a sample prior to ordering.

- Legend:
- Colours available EchoPanel®
 - Colours available Mura™

ECHOPANEL[®] and MURA[™] COLOUR RANGE



500 ● 101 ●● 908 ●● 454 ●● 468 ●

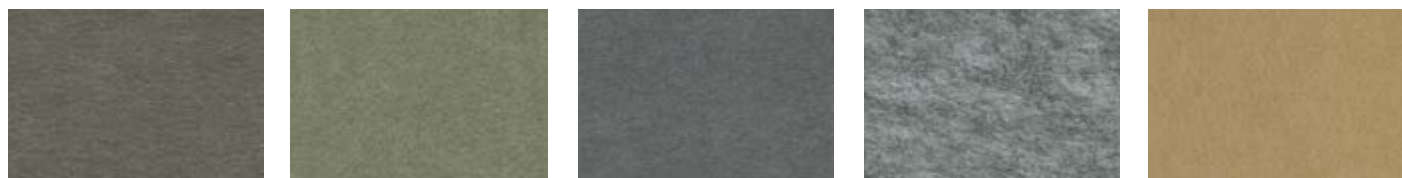

402 ●● 580 ● 444 ●● 442 ●● 458 ●



550 ●● 542 ●● 276 ● 576 ● 274 ●



384 ● 579 ● 381 ● 108 ● 124 ●



330 ●● 349 ●● 577 ● 338 ● 325 ●



269 ●● 193 ● 295 ● 487 ●●



365 ●● 660 ● 551 ●● 633 ●

ECHO™ TILE COLLECTION



Hex Tiles in colourways #580, #579 & #381

Product Name:	Delta Oblong Square Hex Penta
Colours:	All 31 colours in the EchoPanel® range - see page 5
NRC:	0.45 with no air gap
Quality:	Delta - box of 20 tiles Oblong - box of 20 tiles Square - box of 10 tiles Hex - box of 10 tiles Penta - box of 10 tiles

Tile dimensions may vary +/- 2mm.
Actual product may vary in colour from the images shown throughout this brochure.
Please contact us for a sample prior to ordering.

ECHO™ TILE COLLECTION

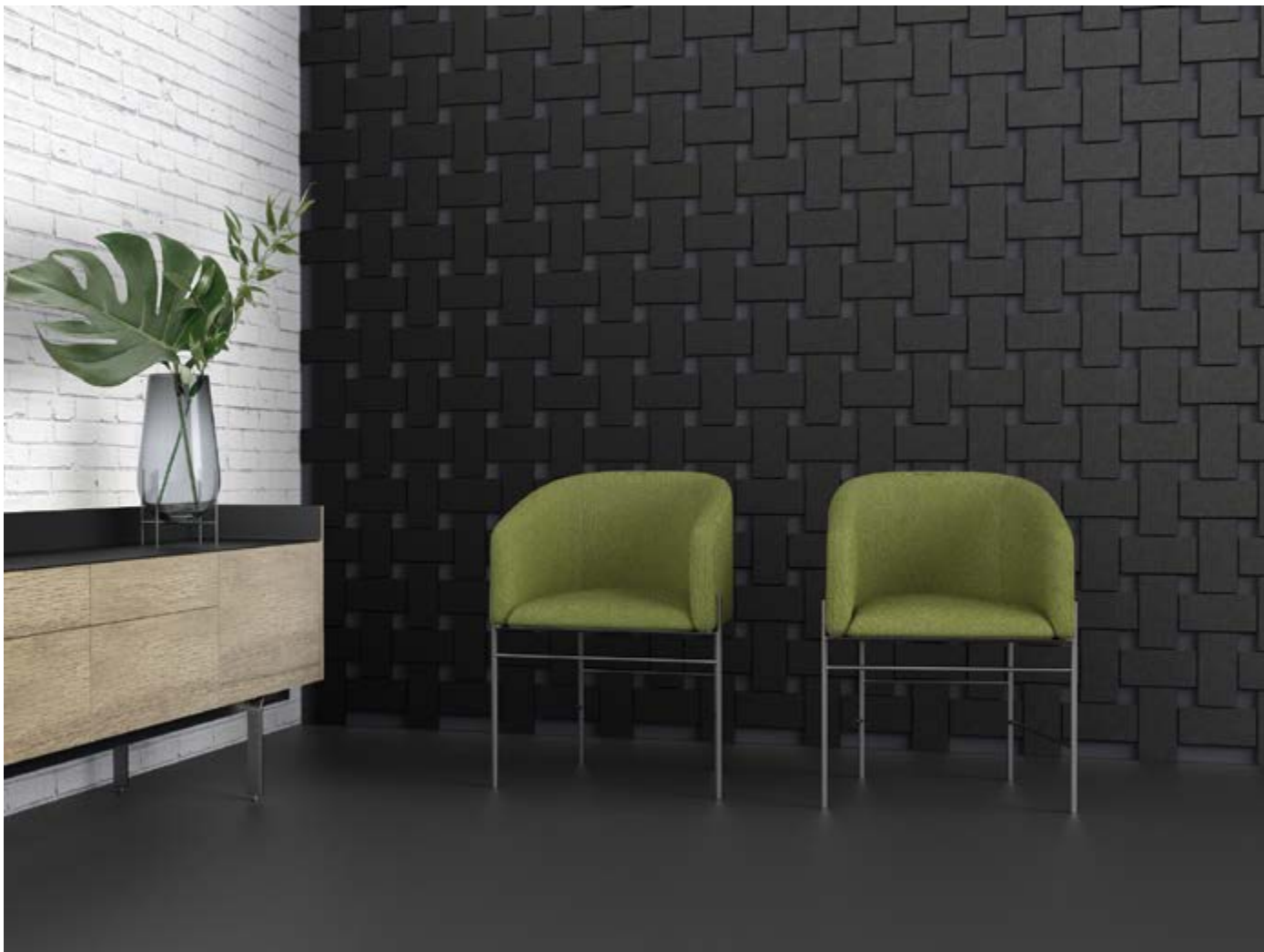

Oblong Tiles in colourway #542

Delta

Corner radius:

5MM & 2.5MM

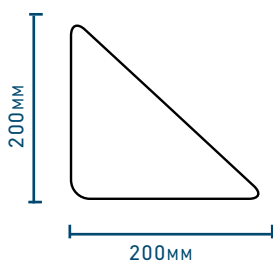

Oblong

Corner radius:

5MM

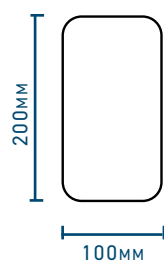

Square

Corner radius:

5MM

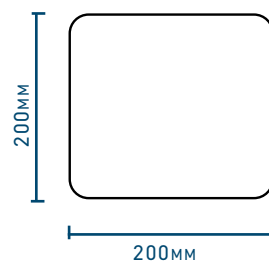

Hex

Corner radius:

30MM

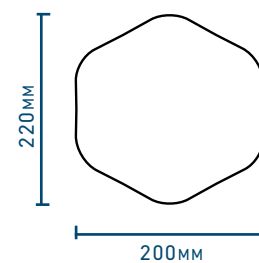

Penta

Corner radius:

25MM

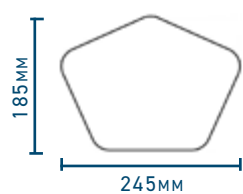

BALANCE COLLECTION



Balance 1300 and 325 tiles in colourway #384 and #454

Product Name: **Balance 325**
Balance 650
Balance 1300

Colours: 15 colours in the **EchoPanel®** range - see page 5
#101 / #269 / #325 / #330 / #365 / 384 / #402 / #442 / #454 / #468 / #487 / #542
#550 / #633 / #908

NRC: 0.65 with no air gap

Quality: **Balance 325** - box of 16 tiles
Balance 650 - box of 8 tiles
Balance 1300 - box of 4 tiles

Tile dimensions may vary +/- 2mm.
Actual product may vary in colour from the images shown throughout this brochure.
Please contact us for a sample prior to ordering.

BALANCE COLLECTION



Balance 1300 tiles in colourway #269

Balance 325

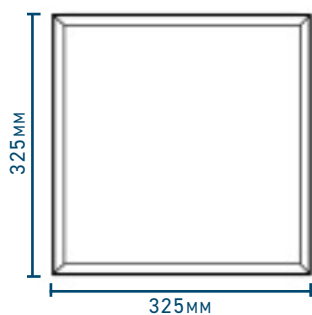

Balance 650

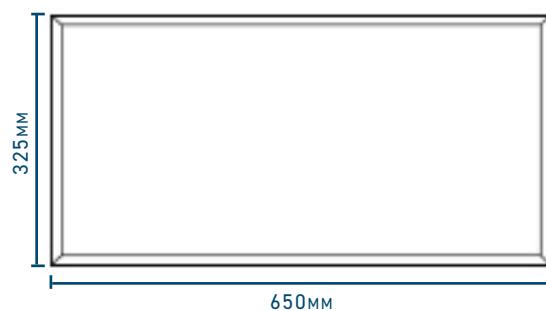

Balance 1300

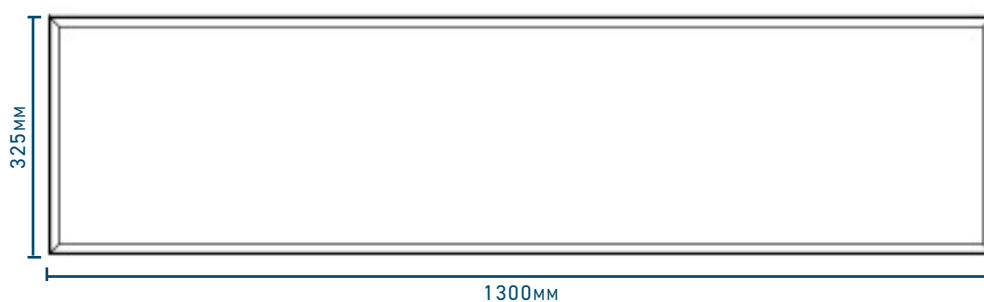

GROOVE 45 COLLECTION



Groove 45 tiles in colourway #551

- Product Name:** Groove 45
- Colours:** 15 colours in the **EchoPanel®** range - see page 5
#101 / #276 / #295 / #330 / #338 / #365 / #381 / #402 /
#442 / #444 / #454 / #500 / #551 / #542 / #908
- Also available in the full **EchoPanel®** colour range, subject to minimum order quantities. Please discuss your project requirements with your local Woven Image representative.
- NRC:** 0.45 with no air gap
- Quantity:** Box of 10 tiles

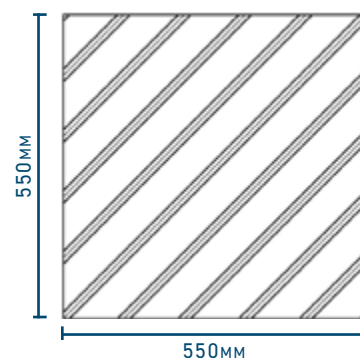

Tile dimensions may vary +/- 2mm.
Actual product may vary in colour from the images shown throughout this brochure.
Please contact us for a sample prior to ordering.

GROOVE 90 COLLECTION



Groove 90 Tiles in colourway #101

Product Name:

Groove 90

Colours:

15 colours in the **EchoPanel®** range - see page 5
#101 / #276 / #295 / #330 / #338 / #365 / #381 / #402 /
#442 / #444 / #454 / #500 / #551 / #542 / #908

Also available in the full **EchoPanel®** colour range, subject to minimum order quantities. Please discuss your project requirements with your local Woven Image representative.

NRC:

0.45 with no air gap

Quantity:

Box of 10 tiles

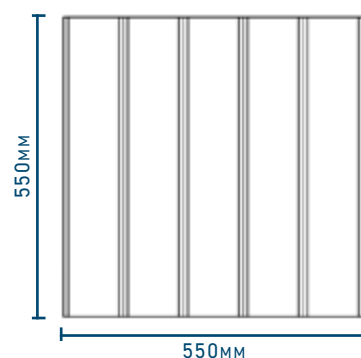

VEE COLLECTION



Vee tiles in colourway #338

Product Name: **Vee**

Colours: 15 colours in the **EchoPanel®** range - see page 5
#101 / #276 / #295 / #330 / #338 / #365 / #381 / #402 /
#442 / #444 / #454 / #500 / #551 / #542 / #908

Also available in the full **EchoPanel®** colour range, subject to minimum order quantities. Please discuss your project requirements with your local Woven Image representative.

NRC: 0.45 with no air gap

Quantity: Box of 10 tiles

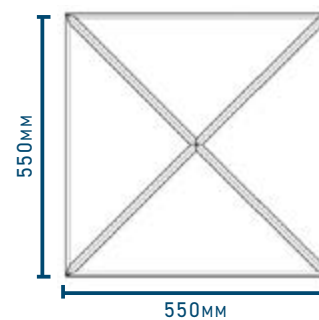

Tile dimensions may vary +/- 2mm.
Actual product may vary in colour from the images shown throughout this brochure.
Please contact us for a sample prior to ordering.

ASCENT COLLECTION



Ascent tiles in colourway #269

PRODUCT NAME: AscentT
Colours: 9 colours
 #101 / #269 / #349 / #458 / #487 / #501 / #542 / #577 / #908
Components: Includes 16 installation clips
NRC: 0.70 (tile only)
 0.90 (tile with optional infill). Order Separately
Quantity: Box of 6 tiles

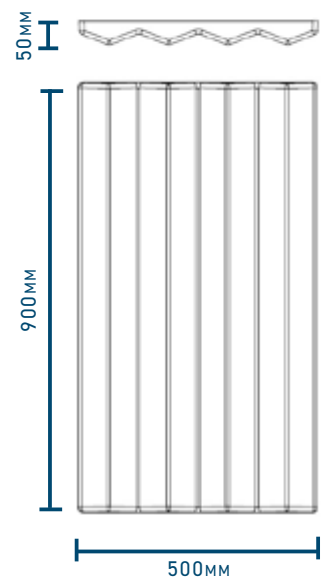

501



101



577



349



908



458



487



269



542

DUNE COLLECTION



Dune tiles in colourway #908

- Product Name: **Dune**
- Colours: 8 colours in the Mura™ range - see page 5
#101 / #269 / #349 / #458 / #487 / #577 / #542 / #908
- Components: Includes 16 installation clips
- NRC: 0.60 with no air gap
- Quantity: box of 9 tiles

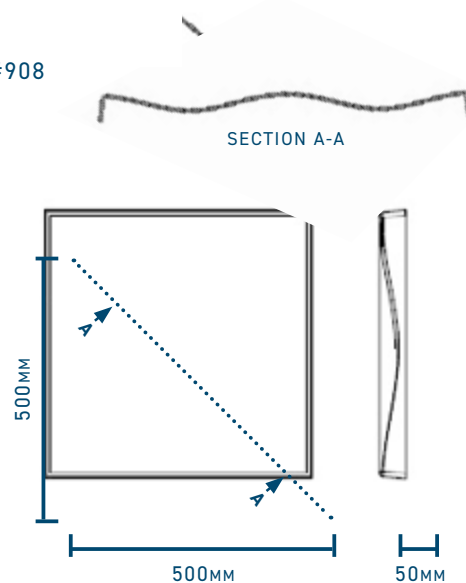
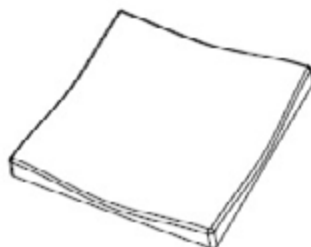

Tile dimensions may vary +/- 2mm.
Actual product may vary in colour from the images shown throughout this brochure.
Please contact us for a sample prior to ordering.

WAVE COLLECTION



Wave tiles in colourway #577

- Product Name: **Wave**
- Colours: 8 Colours in the Mura™ range - see page 5
#101 / #269 / #349 / #458 / #487 / #577 / #542 / #908
- Components: Includes 16 installation clips
- NRC: 0.55 with no air gap
- Quantity: box of 9 tiles

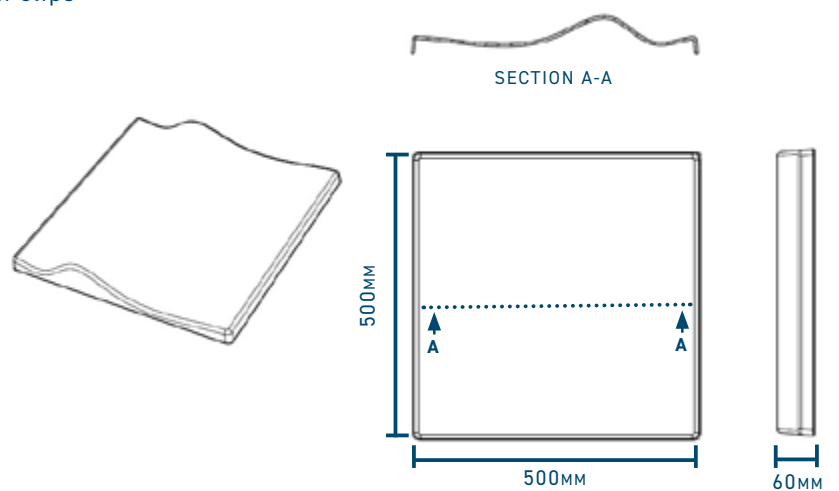

KALEIDOSCOPE COLLECTION

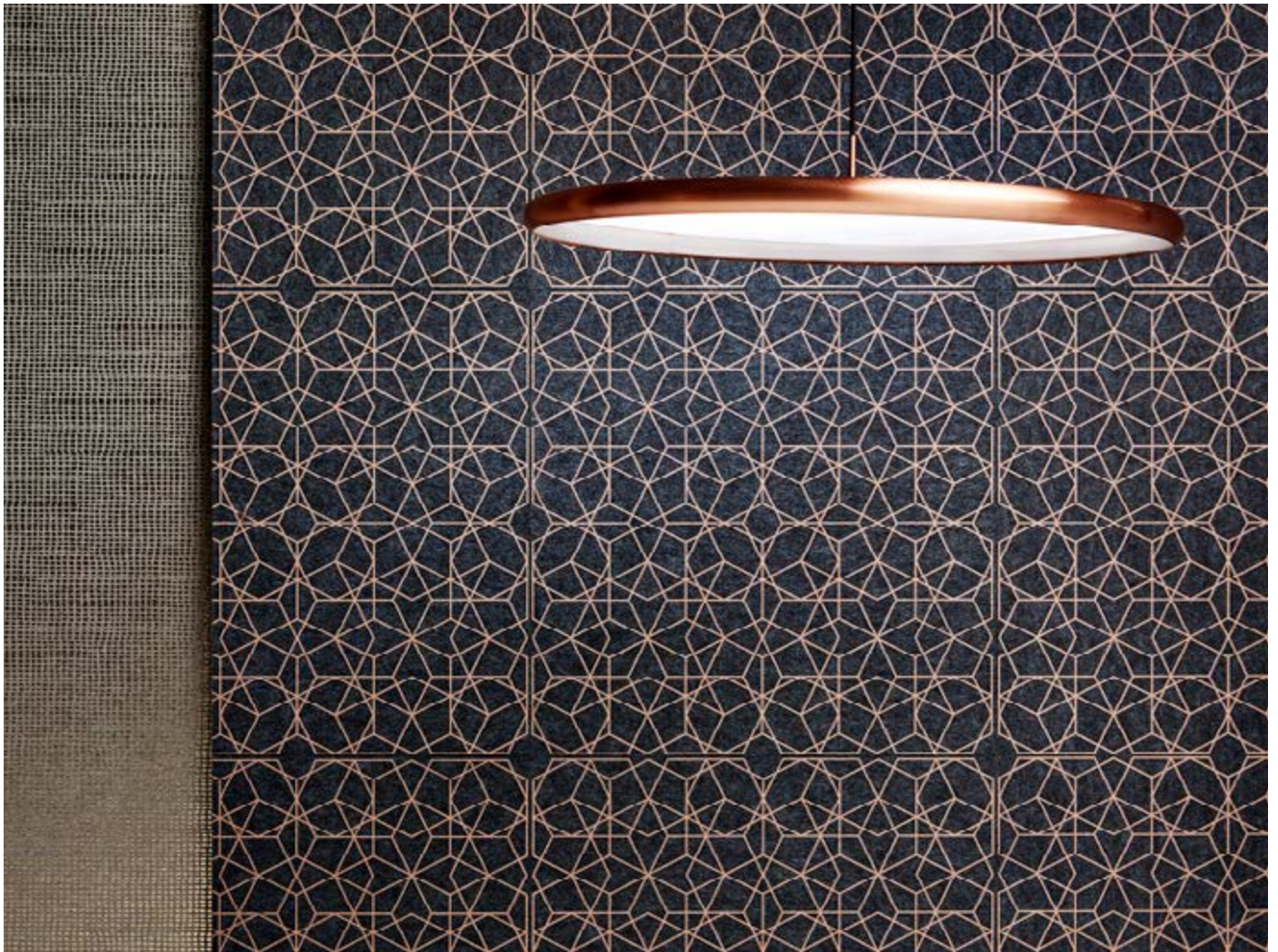

Kaleidoscope tiles in colourway #201

Product Name: **Kaleidoscope**
 Colours: 6
 Pattern Repeat: One tile - 550MM (+/- 2MM) x 550MM (+/- 2MM)
 NRC: 0.30 with no air gap
 Quality: Box of 10 tiles

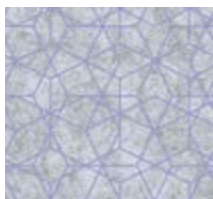
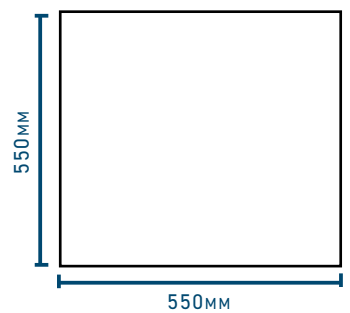

276 (pearlescent ink)



468



384 (pearlescent ink)



201 (pearlescent ink)

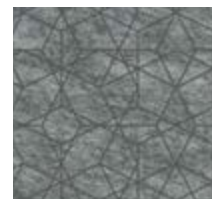

447



330 (pearlescent ink)

Tile dimensions may vary +/- 2mm.
 Actual product may vary in colour from the images shown throughout this brochure.
 Please contact us for a sample prior to ordering.

ACOUSTIC TILE COLLECTION

SPECIFICATIONS

PRODUCT:	ECHO™TILE COLLECTION	BALANCE	GROOVE 45 & GROOVE 90
DESIGNER:	WOVEN IMAGE	WOVEN IMAGE	WOVEN IMAGE
ORIGIN:	MADE IN AUSTRALIA	MADE IN AUSTRALIA	MADE IN AUSTRALIA
COLOURS:	31	15	15
DIMENSIONS:	SEE PAGES 6	SEE PAGE 8	550MM (+/- 2MM) x 550MM (+/- 2MM)
COMPOSITION:	100% PET (60% RECYCLED)	100% PET (60% RECYCLED)	100% PET (60% RECYCLED)
WEIGHT:	APPROX. 2400G/M ² (+/- 10%)	APPROX. 5.07KG PER BOX	APPROX. 8.5KG PER BOX
THICKNESS:	12MM (+/- 7%)	24MM (+/- 7%)	12MM (+/- 7%)
TILES PER BOX:	BOX OF 10 (FOR HEX, PENTA, SQUARE) BOX OF 20 (FOR DELTA, OBLONG)	BOX OF 16 (for BALANCE 325) BOX OF 8 (for BALANCE 650) BOX OF 4 (for BALANCE 1300)	BOX OF 10

PERFORMANCE

COLOUR FASTNESS:	ISO 105-B02-1994 RATING: 6-7	ISO 105-B02-1994 RATING: 6-7	ISO 105-B02-1994 RATING: 6-7
FIRE TEST:	ECHOPANEL® 12MM ACHIEVES: ISO 9705: GROUP 1 AS 1530.3, GB 8624 B1, BS EN 13501.1: CLASSIFICATION B-s1, d0	ISO 9705: GROUP 1 ASTM E84 UNADHERED: CLASS 2 OR B	ECHOPANEL® 12MM ACHIEVES: ISO 9705: GROUP 1 AS 1530.3, GB 8624 B1 BS EN 13501.1: CLASSIFICATION B-s1, d0
SOUND ABSORPTION:	ECHOPANEL® 12MM ACHIEVES: AS ISO 354 - 2006 NRC VALUE: 0.45 (WITH NO AIR GAP)	AS ISO 354 - 2006 NRC VALUE: 0.65 (WITH NO AIR GAP)	ECHOPANEL® 12MM ACHIEVES: AS ISO 354 - 2006 NRC VALUE: 0.45 (WITH NO AIR GAP)
VOC EMISSIONS:	ASTM D5116 RATE: LESS THAN 0.02 MG/M ² /HR (7 DAYS)	ASTM D5116 RATE: LESS THAN 0.02 MG/M ² /HR (7 DAYS)	ASTM D5116 RATE: LESS THAN 0.02 MG/M ² /HR (7 DAYS)
ENVIRONMENTAL:	ECHOPANEL® ACHIEVES GREEN TAG CERTIFICATION GREEN RATE: LEVEL A	ECHOPANEL® ACHIEVES GREEN TAG CERTIFICATION GREEN RATE: LEVEL A	ECHOPANEL® ACHIEVES GREEN TAG CERTIFICATION GREEN RATE: LEVEL A
			

ACOUSTIC TILE COLLECTION

SPECIFICATIONS

PRODUCT:	VEE	ASCENT	DUNE & WAVE
DESIGNER:	WOVEN IMAGE	WOVEN IMAGE	BANG DESIGN FOR WOVEN IMAGE
ORIGIN:	MADE IN AUSTRALIA	MADE IN AUSTRALIA	MADE IN AUSTRALIA
COLOURS:	15	9	8
DIMENSIONS:	550MM (+/- 2MM) x 550MM (+/- 2MM)	500MM (+/- 2MM) x 900MM (+/- 5MM)	500MM (+/- 2MM) x 500MM (+/- 2MM)
COMPOSITION:	100% PET (60% RECYCLED)	3D-FORMED TILE: 100% PET (67% RECYCLED)	3D-FORMED TILE: 100% PET (45% RECYCLED)
WEIGHT:	APPROX. 8.5KG PER BOX	APPROX. 5KG PER BOX	APPROX. 4KG PER BOX
THICKNESS:	12MM (+/- 7%)	4MM (+/- 0.5MM) - MEASURED 10MM ABOVE TRIMMED EDGE. OVERALL TILE DEPTH 50MM (+/- 5MM)	4MM (+/- 0.5MM) - MEASURED 10MM ABOVE TRIMMED EDGE. OVERALL TILE DEPTH 50MM (+/- 2.5MM) DUNE / 60MM (+/- 2.5MM)WAVE
TILES PER BOX:	BOX OF 10	BOX OF 6	BOX OF 9
ADDITIONAL INFORMATION:		INCLUDES 16 CLIPS (4x CLIP A, 8x CLIP B, 4x CLIP C) & CLIP LAYOUT TEMPLATE	INCLUDES 16 CLIPS (4x CLIP A, 8x CLIP B, 4x CLIP C) & CLIP LAYOUT TEMPLATE

PERFORMANCE

COLOUR FASTNESS:	ISO 105-B02-1994 RATING: 6-7	ISO 105-B02 RATING: 6	ISO 105-B02-1994 RATING: 6
FIRE TEST:	ECHOPANEL® 12MM ACHIEVES: ISO 9705: GROUP 1 AS 1530.3, GB 8624 B1, BS EN 13501.1: CLASSIFICATION B-s1, d0	AS 3837 CLASSIFICATION GROUP: 3 GB 8624 B1	AS 3837: GROUP 3, ASTM E84: CLASS 1, BS 476 PART 7: CLASS 2Y
SOUND ABSORPTION:	ECHOPANEL® 12MM ACHIEVES: AS ISO 354 - 2006 NRC VALUE: 0.45 (WITH NO AIR GAP)	AS ISO 354 - 2006 NRC VALUE: 0.70 (TILE ONLY) NRC VALUE: 0.90 (TILE + OPTIONAL INFILL)	AS ISO 354 - 2006 NRC VALUE: 0.55 (WAVE TILE) NRC VALUE: 0.60 (DUNE TILE) NRC VALUE DEPENDS ON DESIGN CONFIGURATION
VOC EMISSIONS:	ASTM D5116 RATE: LESS THAN 0.02 MG/M ² /HR (7 DAYS)	ASTM D5116 RATE: 0.008MG/M ² /HR (7 DAYS)	ASTM D5116 RATE: LESS THAN 0.07 MG/M ² /HR (7 DAYS)
ENVIRONMENTAL:	ECHOPANEL® ACHIEVES GREEN TAG CERTIFICATION GREEN RATE: LEVEL A	ASCENT TILE ACHIEVES GREEN TAG CERTIFICATION GREEN RATE: LEVEL A	ACHIEVES GREEN TAG CERTIFICATION GREEN RATE: LEVEL A
			

PRODUCT: KALEIDOSCOPE

DESIGNER: WOVEN IMAGE - AMY SAUNDERS

ORIGIN: MADE IN AUSTRALIA

COLOURS: 6

DIMENSIONS: 550MM (+/- 2MM) x 550MM (+/- 2MM)

COMPOSITION: 100% PET (68% RECYCLED)

WEIGHT: APPROX. 7KG PER BOX

THICKNESS: APPROX. 9MM (+/- 7%)

TILES PER BOX: BOX OF 10

ADDITIONAL INFORMATION:

COLOUR FASTNESS: ISO 105-B02-1994 RATING: 6

FIRE TEST: ISO 9705: GROUP 1
BS EN 13501.1:
CLASSIFICATION C-s1,d2
GB 8624 B1

SOUND ABSORPTION: AS ISO 354 - 2006
NRC VALUE: 0.30 (WITH NO AIR GAP)

VOC EMISSIONS: ASTM D5116 RATE:
LESS THAN 0.004 MG/M²/HR
(7 DAYS)

ENVIRONMENTAL: ACHIEVES
GREEN TAG CERTIFICATION
GREEN RATE: LEVEL A



