

# FUJI Array mount (suspended soffit)

## INSTALLATION GUIDE

This guide is presented in good faith to assist in the suspended installation of Fuji tiles. It is not intended as an all-encompassing guide, and a professional qualified installer is recommended for optimum results.

Woven Image accepts no responsibility for installation actions taken or not taken. Please refer to Woven Image Pty Ltd. Terms of Trade.

This installation guide contains only recommendations; if you have any questions about installation techniques please contact your distributor or Woven Image sales representative.

### Please note:

- Please check your order is correct and from the same batch number (if requested).
- No claims will be accepted after the product has been installed.
- Fuji's acoustic performance will alter based on a variety of factors including, tile size and the spacing between them.

## FUJI BOX CONTENTS

### FUJI ROKU

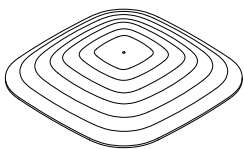

8 x Fuji Roku tiles



8 x Barrel kits

#### TILE SIZE:

560mm (+/-3mm) x 560mm (+/-3mm)  
x 90mm (+/- 3mm)

### FUJI JUNI

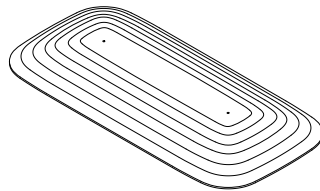

4 x Fuji Juni tiles



8 x Barrel kits

#### TILE SIZE:

560mm (+/-3mm) x 1160mm (+/-3mm)  
x 90mm (+/- 3mm)

### FUJI KU

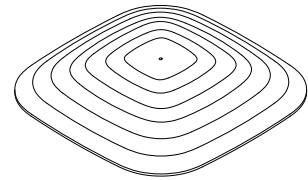

6 x Fuji Ku tiles

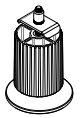

6 x Barrel kits

#### TILE SIZE:

840mm (+/-3mm) x 840mm (+/-3mm)  
x 90mm (+/- 3mm)

## ARRAY HARDWARE BOX CONTENTS

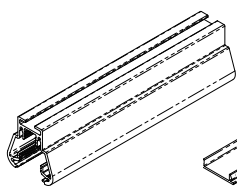

2 x Array rails

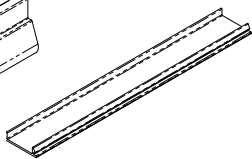

2 x snap covers



4 x end caps



4 x screws

## SUSPENDED SOFFIT BOX CONTENTS



4 x concrete  
dowel



4 x top  
ellipse barrels  
(cable connector)

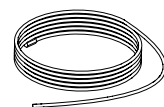

4 x suspension  
cables



4 x bottom  
ellipse barrels  
(cable connector)

## TOOLS REQUIRED

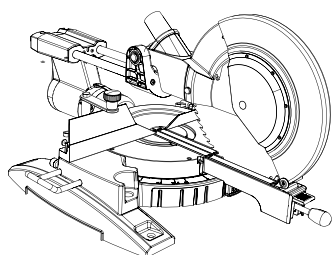

Drop saw

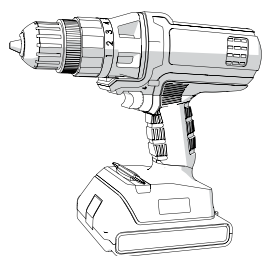

Drill + Allen key head drive

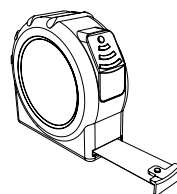

Measuring tape

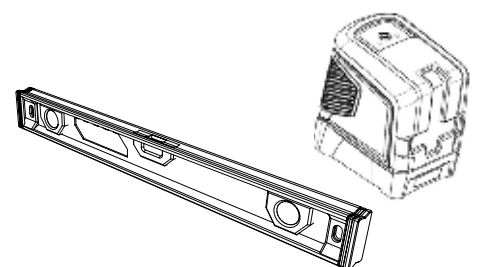

Spirit & Laser levels

# FUJI Array mount (suspended soffit)

## INSTALLATION GUIDE

### Step 1

- Once your product is delivered, please ensure your order is correct and undamaged. Prepare area and lay out all components for use.  
We recommend you use professional qualified installers. Please contact Woven Image for recommendations.

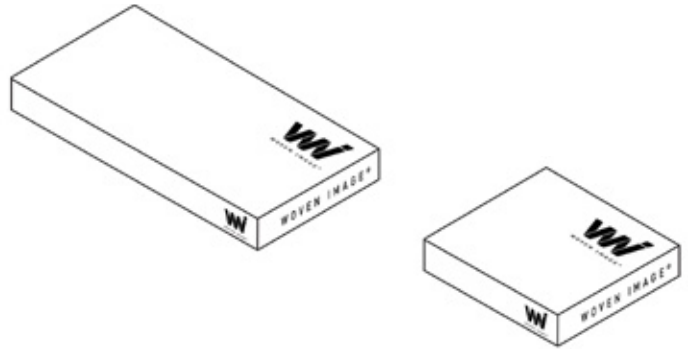

### Step 2

- Ensure the spacing between parallel rails is adequate for your selected tile size. See below for spacing specifications:

#### FUJI ROKU

- Confirm tile spacing and trim snap covers.
- Nominal distance at 600mm centres.
- 600mm centres of tiles = 594mm snap cover.
- 600mm between holes with 2mm tolerance = 592mm snap cover.

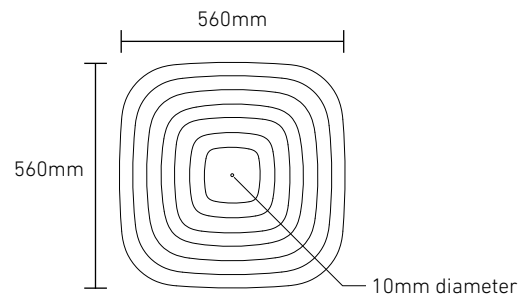

#### FUJI JUNI

- Confirm tile spacing and trim snap covers.
- Nominal distance at 600mm centres.
- 600mm centres of tiles = 594mm snap cover.
- 600mm between holes with 2mm tolerance = 592mm snap cover.

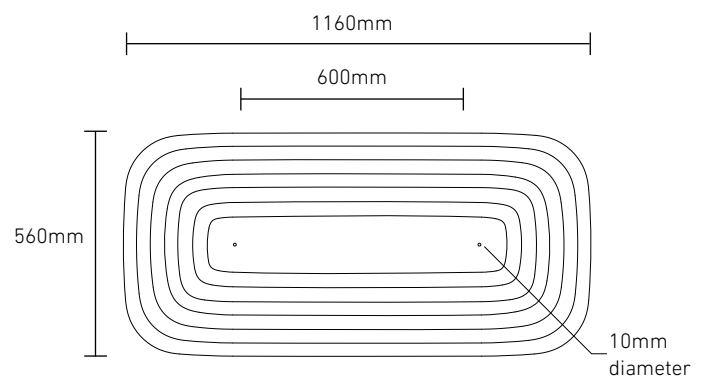

#### FUJI ROKU

- Confirm tile spacing and trim snap covers.
- Nominal distance at 900mm centres
- 900mm centres of tiles = 894mm snap cover.

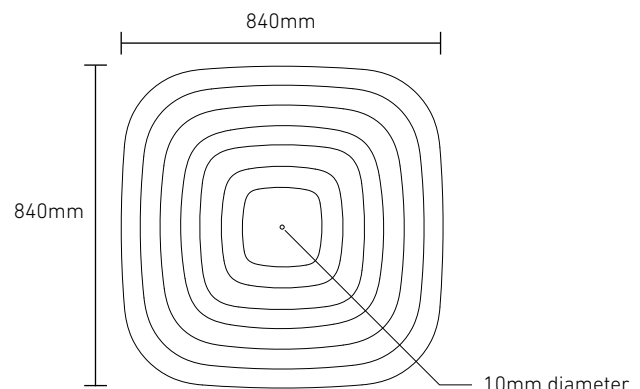

# FUJI Array mount (suspended soffit)

## INSTALLATION GUIDE

### Step 3

- Prepare area and use a laser level to mark out desired location. Inspect ceiling surfaces and structure to ensure it is free from damage and is structurally fit for installation. Level 3 plasterboard finish for a ceiling is recommended.

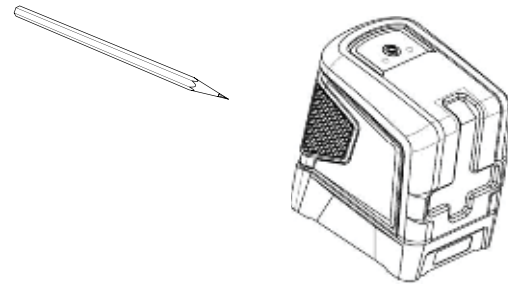

### Step 4

- Drill 30mm deep hole.
- Hammer the concrete dowel into the hole.

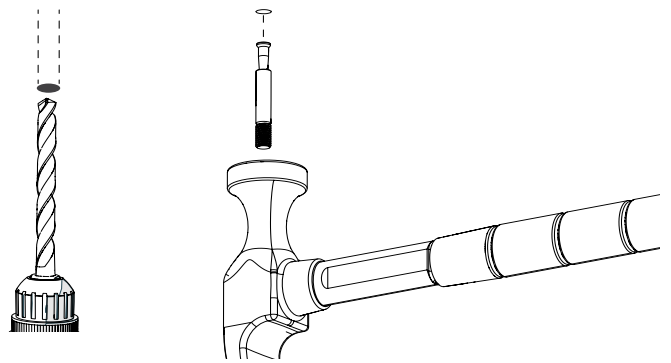

### Step 5

- Attach end caps to lengths that will be at an end of a run.

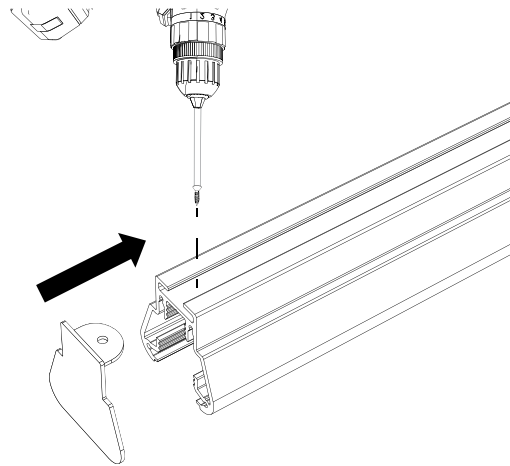

### Step 6

- Insert suspension cable through top ellipse barrel.
- Unscrew the top ellipse cap.
- Feed the cable through.
- Screw top ellipse cap back on.

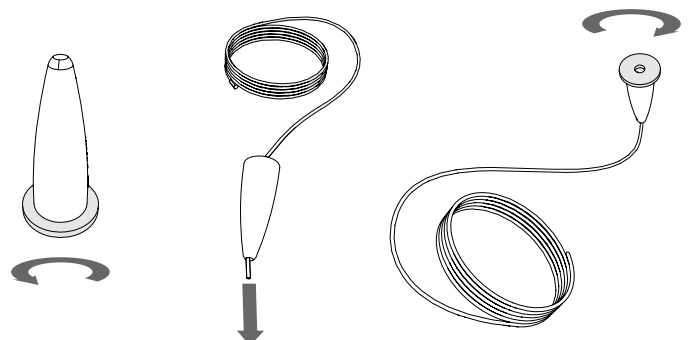

# FUJI Array mount (suspended soffit)

## INSTALLATION GUIDE

### Step 7

- Screw the top ellipse barrel onto dowel. Ensure it is screwed all the way to the top of the dowel.

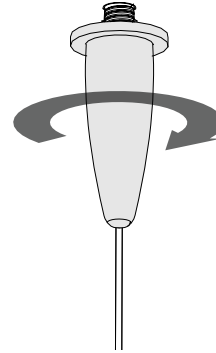

### Step 8

- Repeat step 6 across all locations.

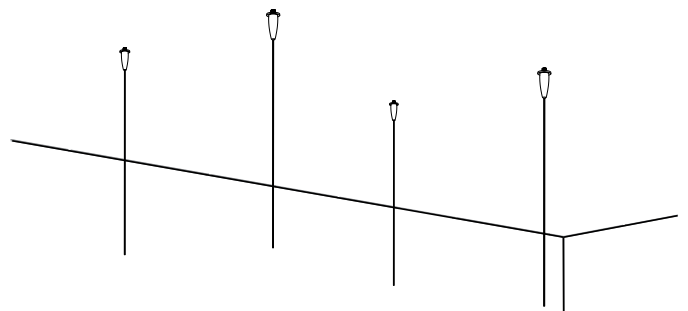

### Step 9

- Slide the bottom ellipse barrels into the bottom of the rail.

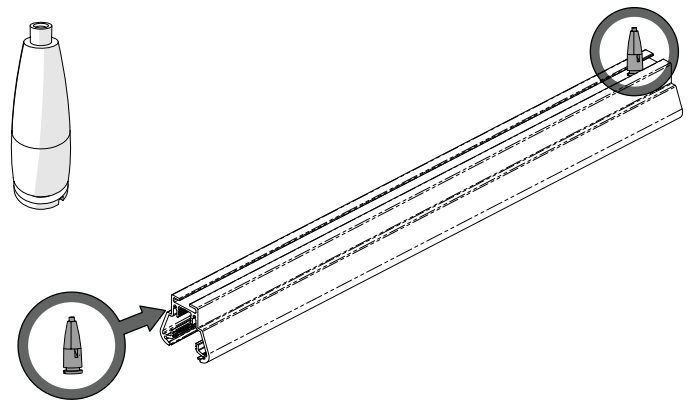

### Step 10

- For modular setup, use a connector plate, available to order separately.

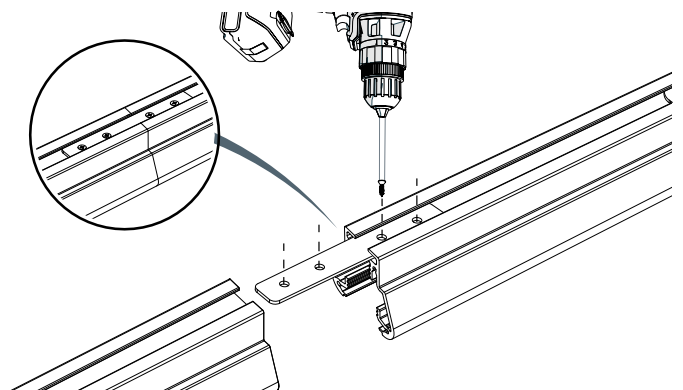

# FUJI Array mount (suspended soffit)

## INSTALLATION GUIDE

### Step 11

- Insert suspension cable through the bottom ellipse barrel already attached to the aluminium rail. Ensure the cable is threaded through the lower hole. Repeat step for all suspension cables.

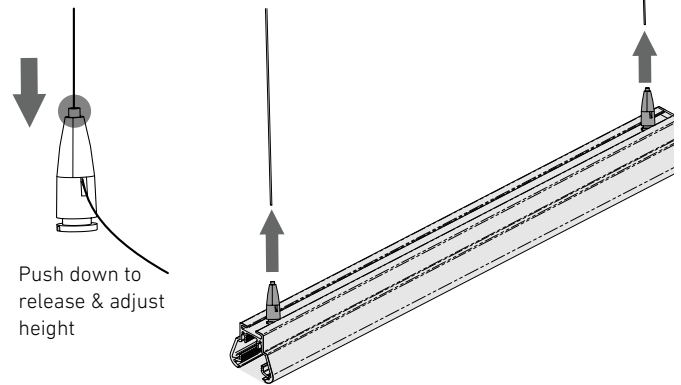

### Step 12

- Whilst supporting the suspension cable firmly with one hand, lift the aluminium rail to the required height ensuring it is level. Repeat steps for all suspension cables.

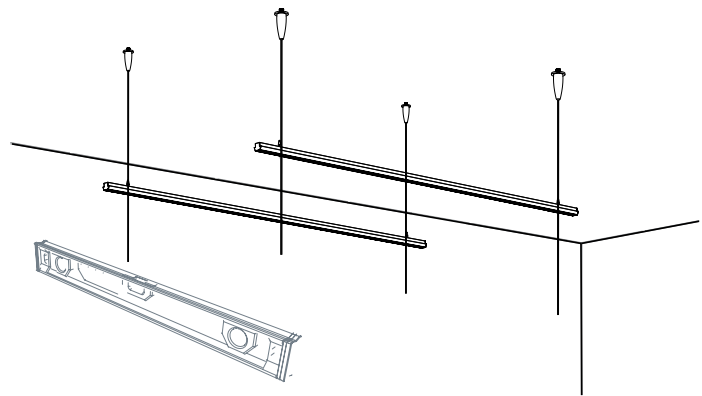

### Step 13

- Ensure all end caps are installed.

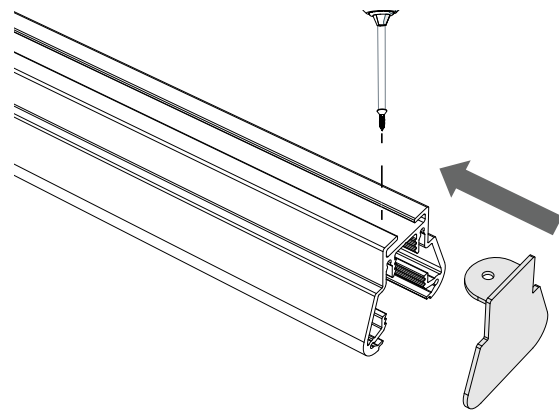

### Step 14

- Adjust barrel kit to suit Array profile opening.

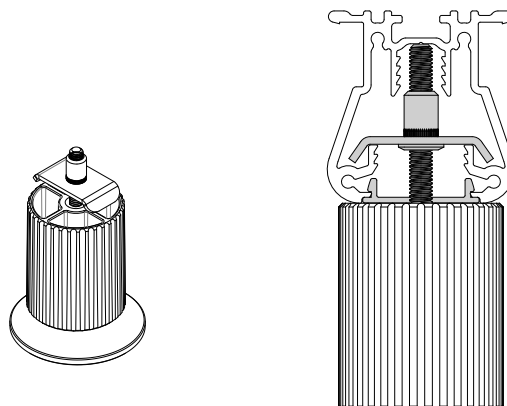

# FUJI Array mount (suspended soffit)

## INSTALLATION GUIDE

### Step 15

- Slide barrel kit and snap covers into Array rail.

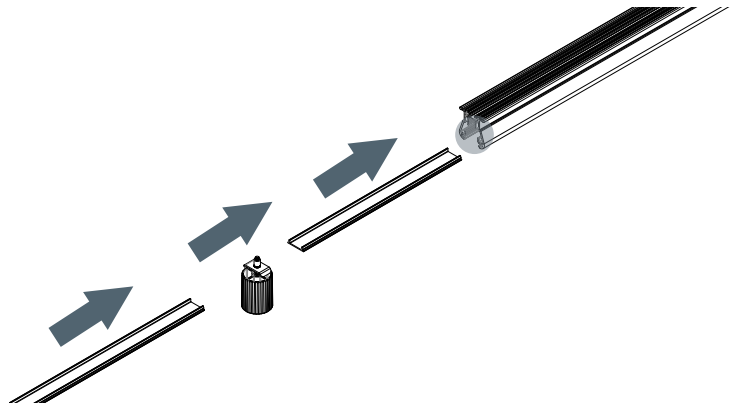

### Step 16

- Tighten the barrel to lock it into place.

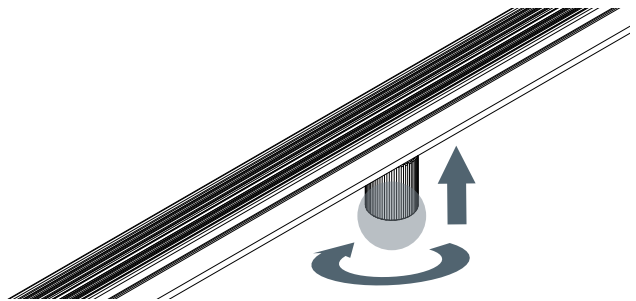

### Step 17

- Remove the button.
- Attach the tile to the barrel using the button thread.
- For faster assembly use a Allen key head with cordless drill to screw the button into location.
- Ensure the drill clutch is set low enough to prevent stripping out the hex recess.

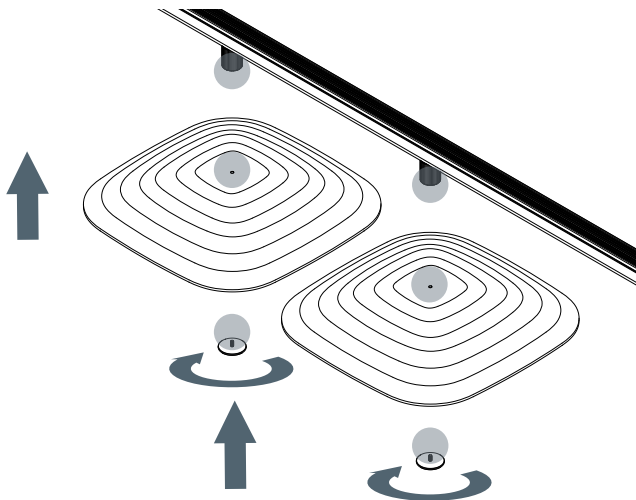

# FUJI Array mount (suspended soffit) INSTALLATION GUIDE

## COMPLETED ASSEMBLY

### FUJI ROKU

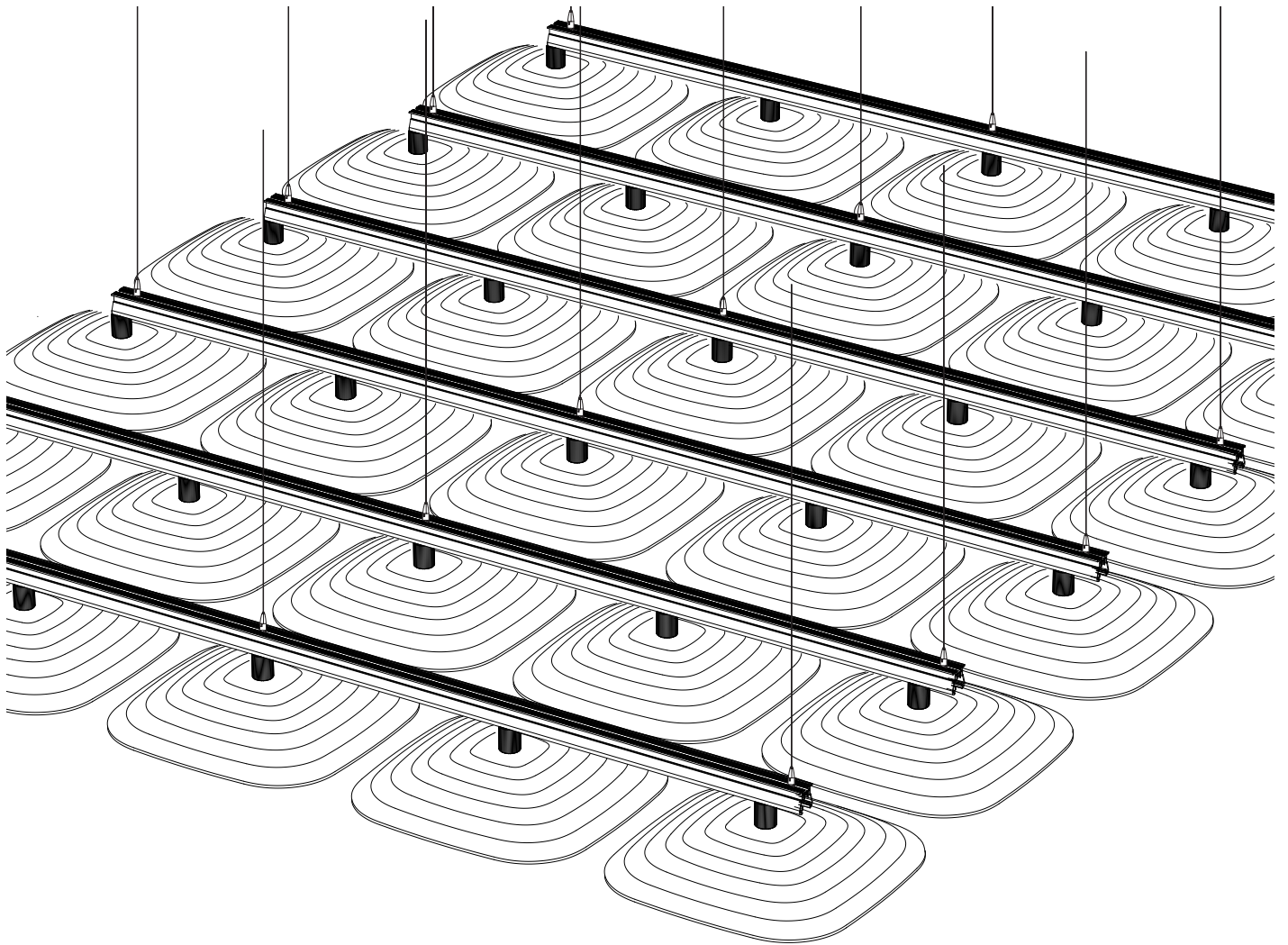

# FUJI Array mount (suspended soffit)

## INSTALLATION GUIDE

### FUJI JUNI

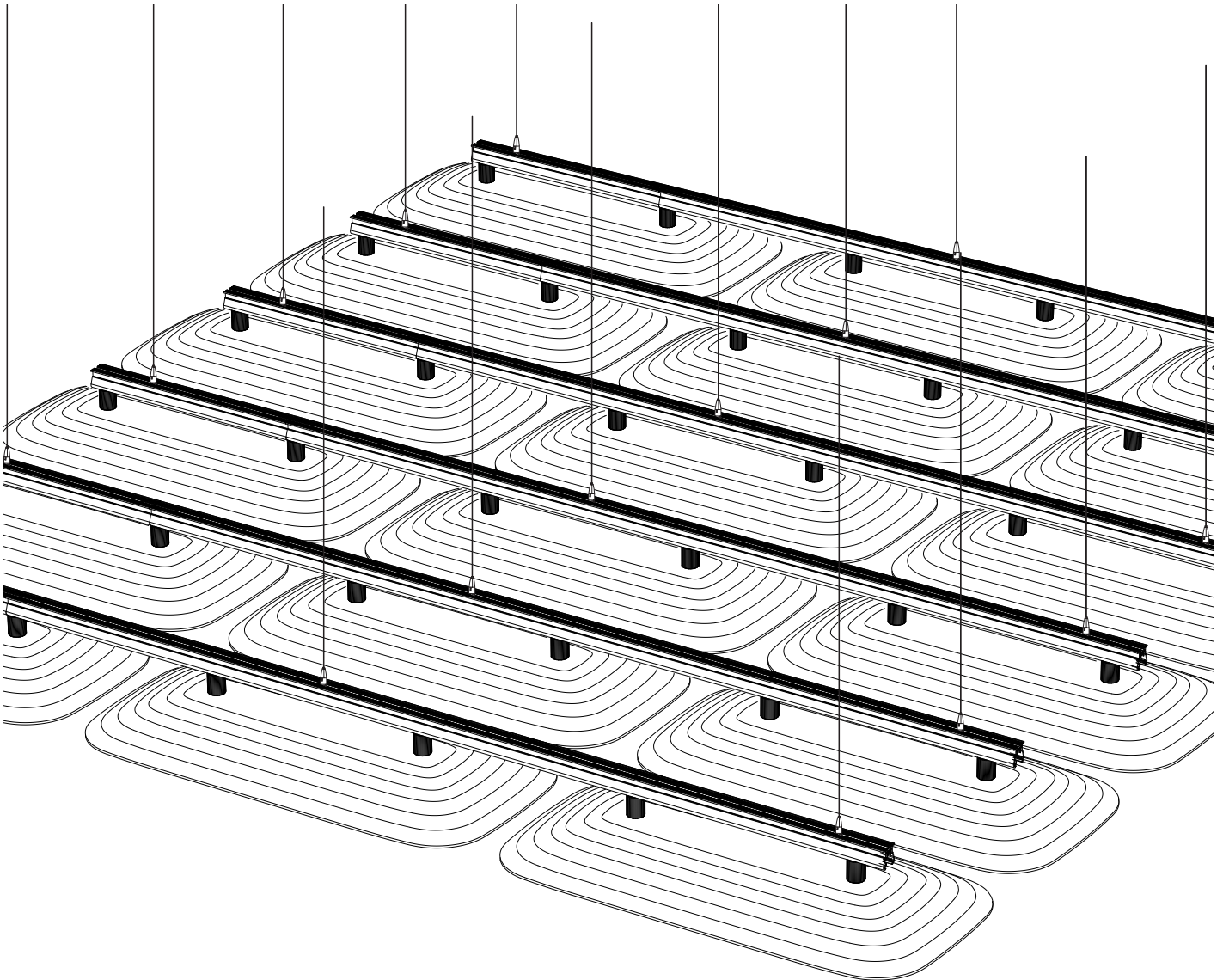



# FUJI Array mount (suspended soffit)

## INSTALLATION GUIDE

### FUJI KU

