

INTERIOR ACOUSTICS 3D TILES



3D TILES
DESIGN: S-5.37 AND S-5.34
COLOR: NOIR, STONEWASH
AND CIVIC



3D TILES

3D Tiles are our stylish and high performing version of wall art. In packs of 6 that include all the fixings you need to install, our lightweight and semi-rigid 3D Tiles are super easy to put up all while giving you the freedom to mix and match both colours and styles. With 15 colours in eight different designs, you can create a feature that reflects your own style and environment.

But they don't only look good, they are high performing as well; specifically designed to reduce and control echo creating a more focused and productive space.

Just like the rest of the interior acoustics range, durability, longevity and performance are assured.

3D TILES

APPLICATIONS

- Decorative and functional acoustic tiles for residential, office, education, retail, hospitality and commercial interiors
- Minimise noise in the interior environment and create unique finishes and features
- Easy dry clip system for installation

SPECIFICATION

Wall treatment shall be 3D Tile series acoustic tile from thermally moulded, needle punched, felted polyester material containing not less than 55% recycled material as manufactured by Autex Industries Ltd. www.autexindustries.com

Tile (S-5-□), colour (□), sound absorption Class C, NRC 0.75 – if backed with Autex AAB: Class A, NRC 0.90. Fire rating ISO 9705: Classification: Group 1-S, EN13501-1:2007+A1:2009: B - s1, d2.

Tiles to be supplied with 1 standard tile clip per tile. Install as per 3D Tile Install Instructions.

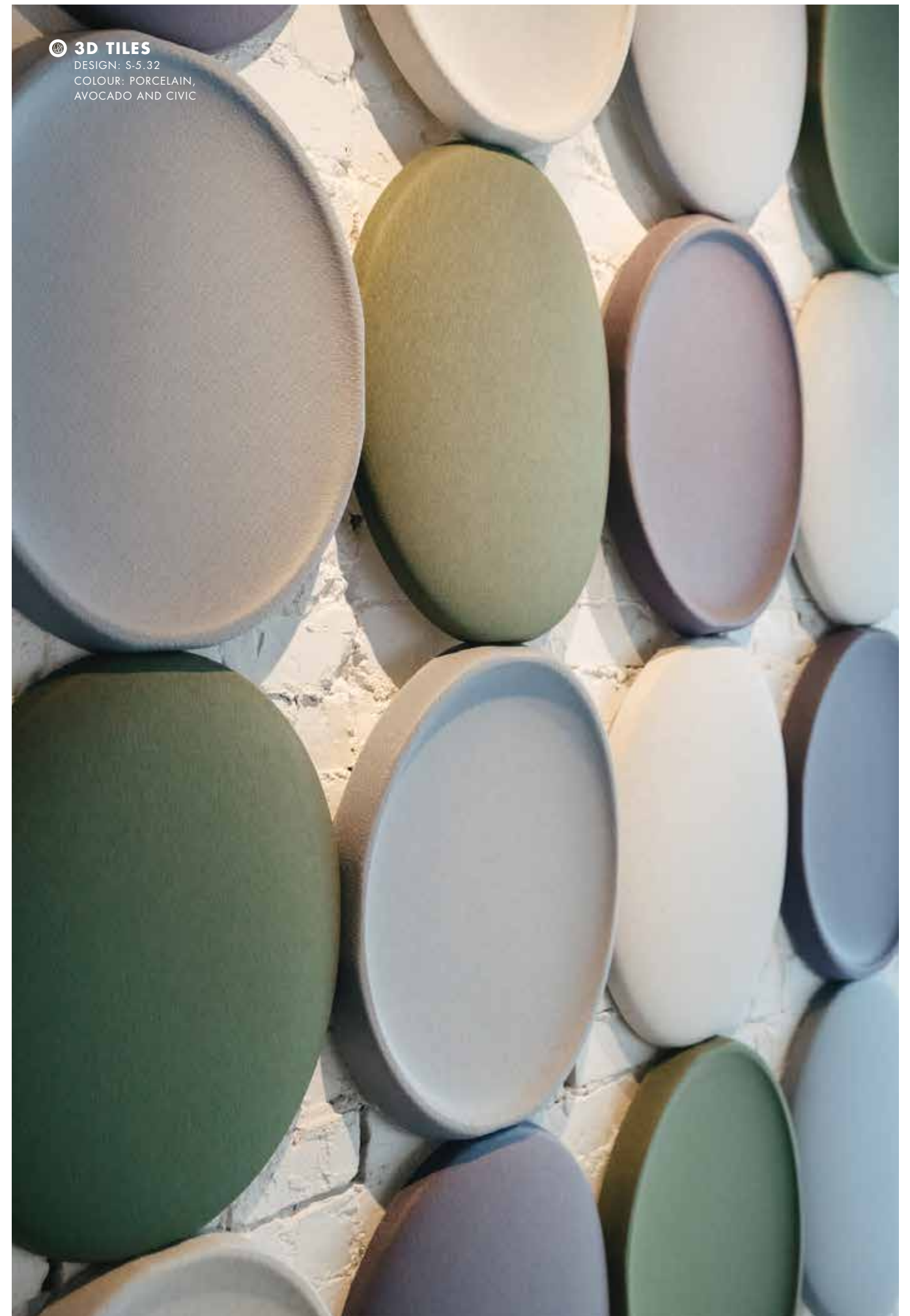

S-5.26 DESIGN

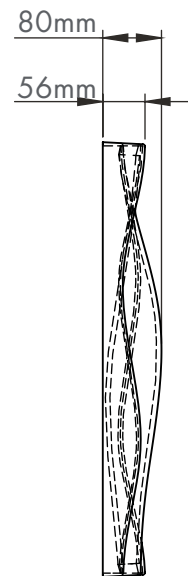
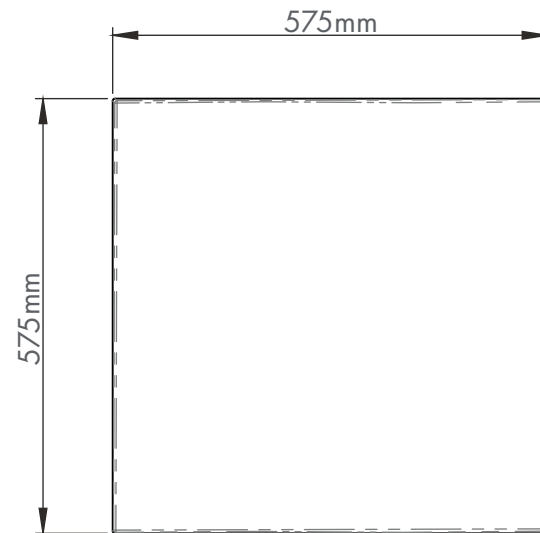

ABSORPTION COEFFICIENT ACCORDING TO ISO 354

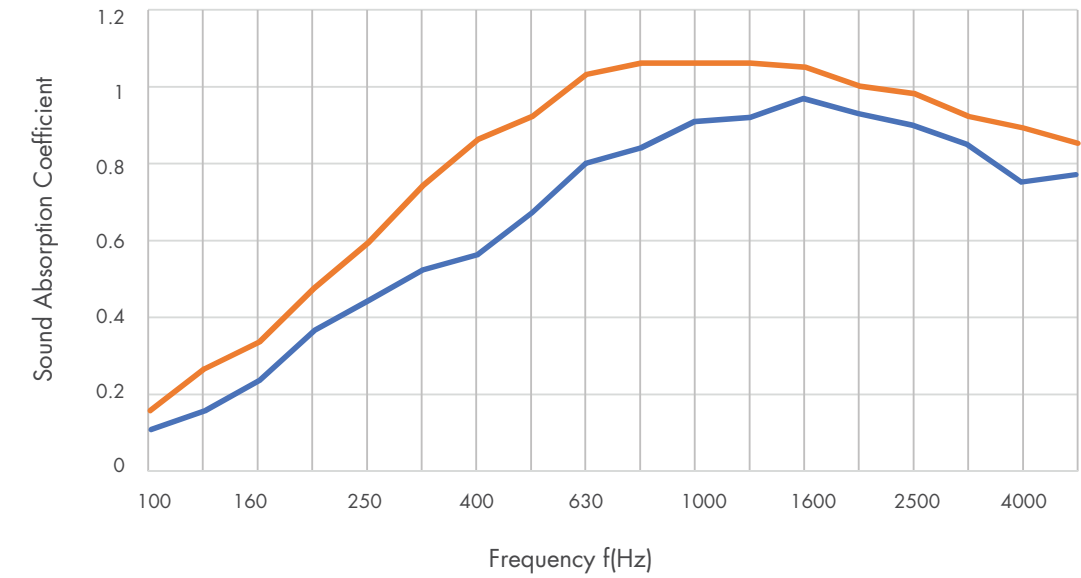

The graph above presents third octave sound absorption coefficients in accordance with ISO 354 measurement of sound absorption in a reverberation room. The table below presents the practical sound absorption coefficients in accordance with ISO 11654. The NRC rating is determined as the arithmetic average of the absorption coefficients measured by one-third octave bands centred on 250 Hz, 500 Hz, 1000 Hz and 2000 Hz and rounded to the nearest 0.05.

Frequency (Hz)	University of Auckland Test Report Number	125	250	500	1000	2000	4000	NRC
3D Tiles without AAB 35-25	T1012-3	0.15	0.45	0.65	0.90	0.90	0.80	0.75
3D Tiles with AAB 35-25	T1012-5	0.25	0.60	0.95	1.05	1.00	0.90	0.90

PRODUCT SPECIFICATIONS

Product Name	3D Tiles S-5.26
Composition	100% Polyester Fibre (PET)
Tile Dimensions	575mm x 575mm
Tile Tolerance	(+0.5mm) (+0.5mm)
Depth	80mm
Depth Tolerance	(+0.5mm)
Weight	1680 GSM

INSTALLATION

Install as per Autex recommendations. Install instructions are included in each pack or available on the website.

ACOUSTIC PERFORMANCE

3D Tiles S-5.26 are specifically designed to reduce and control reverberated noise (echo) in building interiors. To increase acoustic performance, use Autex AAB 35-25 polyester acoustic insulation as an infill. Refer to www.autexindustries.com/greenstuf/greenstuf-aab.

LIGHT REFLECTANCE VALUES BY COLOUR

Civic	57	Avocado	11
Silver	23	Blush	10
Porcelain	22	Blazing Red	8
Fawn	20	Bark	5
Granny Smith	20	Stately	3
Stonewash	19	Charcoal	3
Brilliant Orange	15	Noir	1
Electric Blue	12		

MEASURED IN ACCORDANCE WITH BS 8493:2008+A1:2010

S-5.28 DESIGN

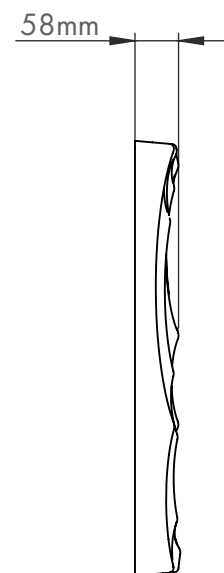
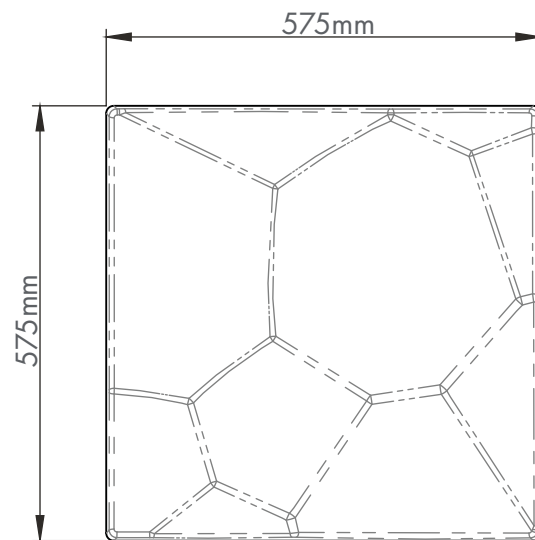

ABSORPTION COEFFICIENT ACCORDING TO ISO 354

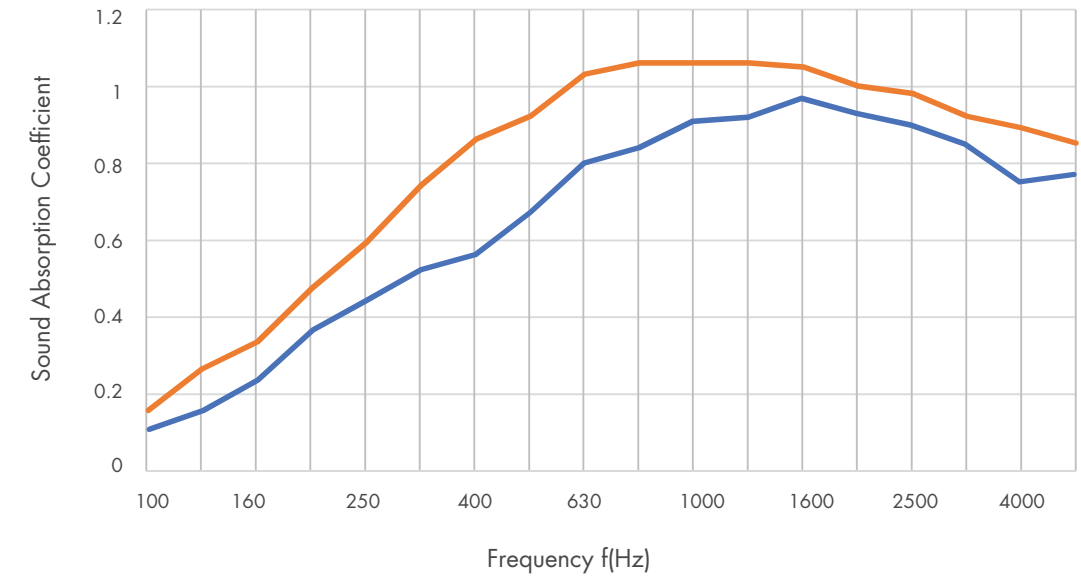

The graph above presents third octave sound absorption coefficients in accordance with ISO 354 measurement of sound absorption in a reverberation room. The table below presents the practical sound absorption coefficients in accordance with ISO 11654. The NRC rating is determined as the arithmetic average of the absorption coefficients measured by one-third octave bands centred on 250 Hz, 500 Hz, 1000 Hz and 2000 Hz and rounded to the nearest 0.05.

Frequency (Hz)	University of Auckland Test Report Number	125	250	500	1000	2000	4000	NRC
3D Tiles without AAB 35-25	T1012-3	0.15	0.45	0.65	0.90	0.90	0.80	0.75
3D Tiles with AAB 35-25	T1012-5	0.25	0.60	0.95	1.05	1.00	0.90	0.90

PRODUCT SPECIFICATIONS

Product Name	3D Tiles S-5.28
Composition	100% Polyester Fibre (PET)
Tile Dimensions	575mm x 575mm
Tile Tolerance	(+0.5mm) (+0.5mm)
Depth	58mm
Depth Tolerance	(+0.5mm)
Weight	1680 GSM

INSTALLATION

Install as per Autex recommendations. Install instructions are included in each pack or available on the website.

ACOUSTIC PERFORMANCE

3D Tiles S-5.28 are specifically designed to reduce and control reverberated noise (echo) in building interiors. To increase acoustic performance, use Autex AAB 35-25 polyester acoustic insulation as an infill. Refer to www.autexindustries.com/greenstuf/greenstuf-aab.

LIGHT REFLECTANCE VALUES BY COLOUR

Civic	57	Avocado	11
Silver	23	Blush	10
Porcelain	22	Blazing Red	8
Fawn	20	Bark	5
Granny Smith	20	Stately	3
Stonewash	19	Charcoal	3
Brilliant Orange	15	Noir	1
Electric Blue	12		

MEASURED IN ACCORDANCE WITH BS 8493:2008+A1:2010

S-5.32 DESIGN

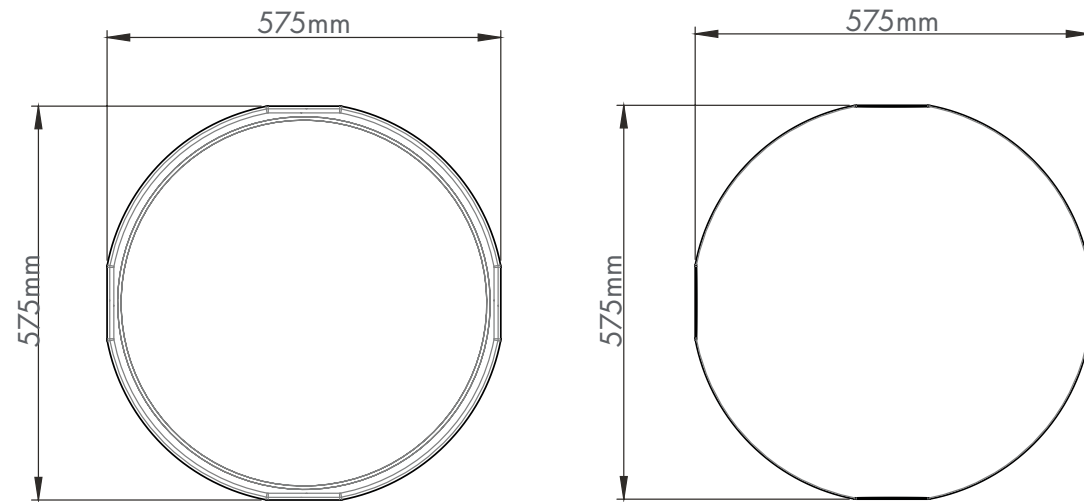

CONCAVE

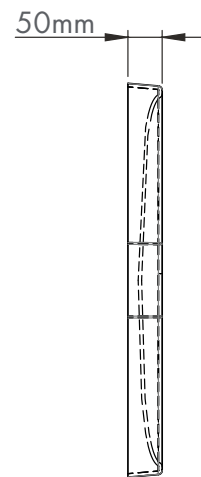

CONVEX

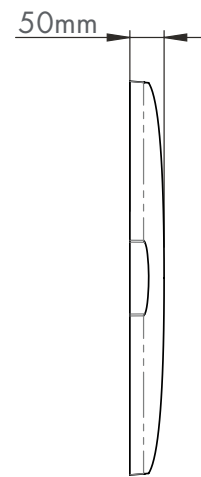

ABSORPTION COEFFICIENT ACCORDING TO ISO 354

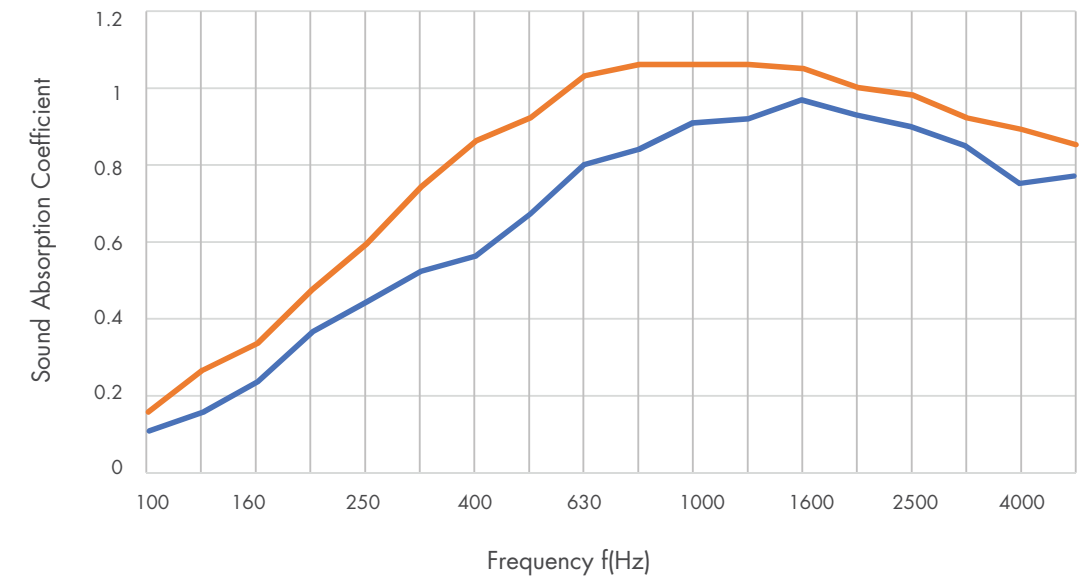

The graph above presents third octave sound absorption coefficients in accordance with ISO 354 measurement of sound absorption in a reverberation room. The table below presents the practical sound absorption coefficients in accordance with ISO 11654. The NRC rating is determined as the arithmetic average of the absorption coefficients measured by one-third octave bands centred on 250 Hz, 500 Hz, 1000 Hz and 2000 Hz and rounded to the nearest 0.05.

Frequency (Hz)	University of Auckland Test Report Number	125	250	500	1000	2000	4000	NRC
3D Tiles without AAB 35-25	T1012-3	0.15	0.45	0.65	0.90	0.90	0.80	0.75
3D Tiles with AAB 35-25	T1012-5	0.25	0.60	0.95	1.05	1.00	0.90	0.90

PRODUCT SPECIFICATIONS

Product Name	3D Tiles S-5.32
Composition	100% Polyester Fibre (PET)
Tile Dimensions	575mm x 575mm
Tile Tolerance	(+0.5mm) (+0.5mm)
Depth	50mm
Depth Tolerance	(+0.5mm)
Weight	1680 GSM

INSTALLATION

Install as per Autex recommendations. Install instructions are included in each pack or available on the website.

ACOUSTIC PERFORMANCE

3D Tiles S-5.32 are specifically designed to reduce and control reverberated noise (echo) in building interiors. To increase acoustic performance, use Autex AAB 35-25 polyester acoustic insulation as an infill. Refer to www.autexindustries.com/greenstuf/greenstuf-aab.

LIGHT REFLECTANCE VALUES BY COLOUR

Civic	57	Avocado	11
Silver	23	Blush	10
Porcelain	22	Blazing Red	8
Fawn	20	Bark	5
Granny Smith	20	Stately	3
Stonewash	19	Charcoal	3
Brilliant Orange	15	Noir	1
Electric Blue	12		

MEASURED IN ACCORDANCE WITH BS 8493:2008+A1:2010

S-5.34 DESIGN

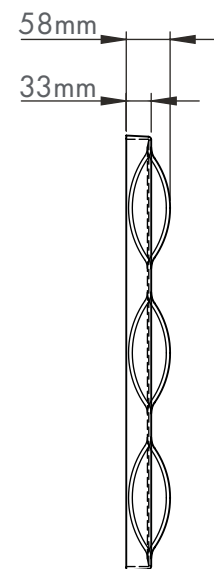
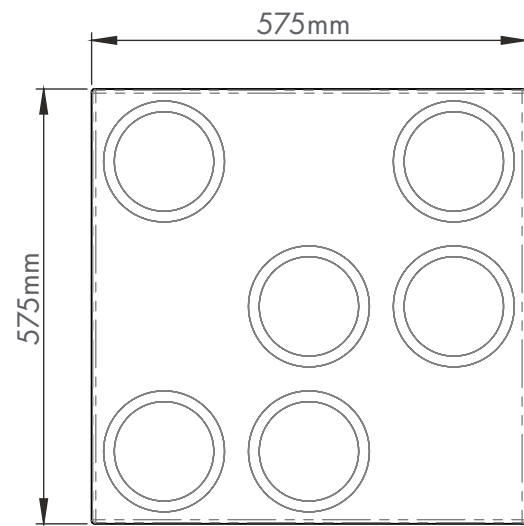

ABSORPTION COEFFICIENT ACCORDING TO ISO 354

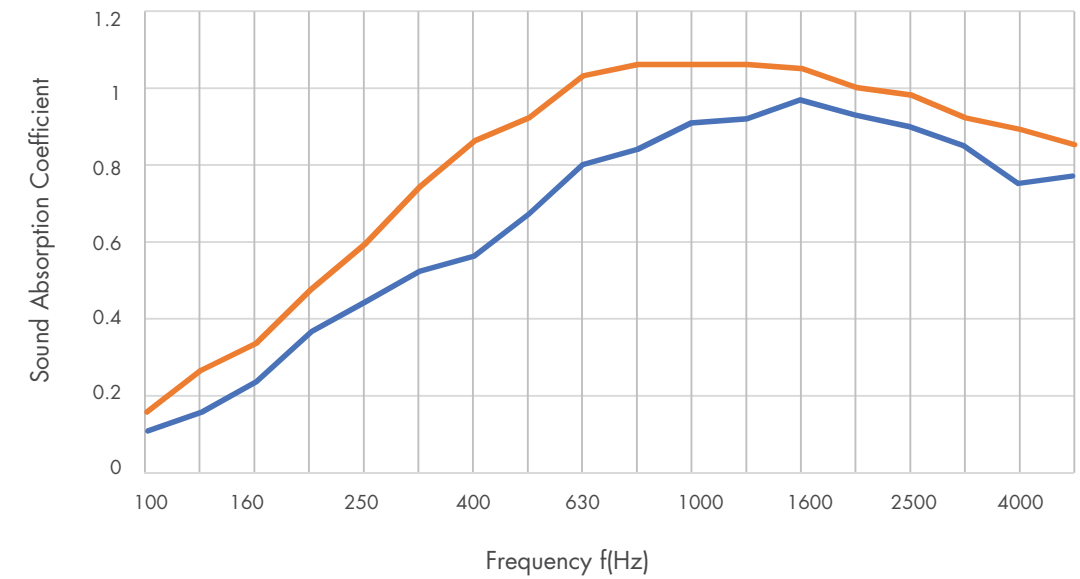

The graph above presents third octave sound absorption coefficients in accordance with ISO 354 measurement of sound absorption in a reverberation room. The table below presents the practical sound absorption coefficients in accordance with ISO 11654. The NRC rating is determined as the arithmetic average of the absorption coefficients measured by one-third octave bands centred on 250 Hz, 500 Hz, 1000 Hz and 2000 Hz and rounded to the nearest 0.05.

Frequency (Hz)	University of Auckland Test Report Number	125	250	500	1000	2000	4000	NRC
3D Tiles without AAB 35-25	T1012-3	0.15	0.45	0.65	0.90	0.90	0.80	0.75
3D Tiles with AAB 35-25	T1012-5	0.25	0.60	0.95	1.05	1.00	0.90	0.90

PRODUCT SPECIFICATIONS

Product Name	3D Tiles S-5.34
Composition	100% Polyester Fibre (PET)
Tile Dimensions	575mm x 575mm
Tile Tolerance	(+0.5mm) (+0.5mm)
Depth	58mm
Depth Tolerance	(+0.5mm)
Weight	1680 GSM

INSTALLATION

Install as per Autex recommendations. Install instructions are included in each pack or available on the website.

ACOUSTIC PERFORMANCE

3D Tiles S-5.34 are specifically designed to reduce and control reverberated noise (echo) in building interiors. To increase acoustic performance, use Autex AAB 35-25 polyester acoustic insulation as an infill. Refer to www.autexindustries.com/greenstuf/greenstuf-aab.

LIGHT REFLECTANCE VALUES BY COLOUR

Civic	57	Avocado	11
Silver	23	Blush	10
Porcelain	22	Blazing Red	8
Fawn	20	Bark	5
Granny Smith	20	Stately	3
Stonewash	19	Charcoal	3
Brilliant Orange	15	Noir	1
Electric Blue	12		

MEASURED IN ACCORDANCE WITH BS 8493:2008+A1:2010

S-5.37 DESIGN

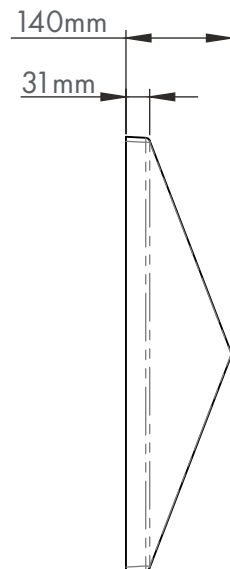
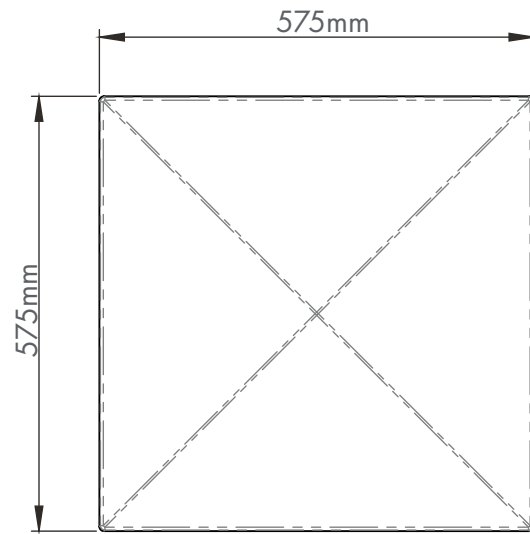

ABSORPTION COEFFICIENT ACCORDING TO ISO 354

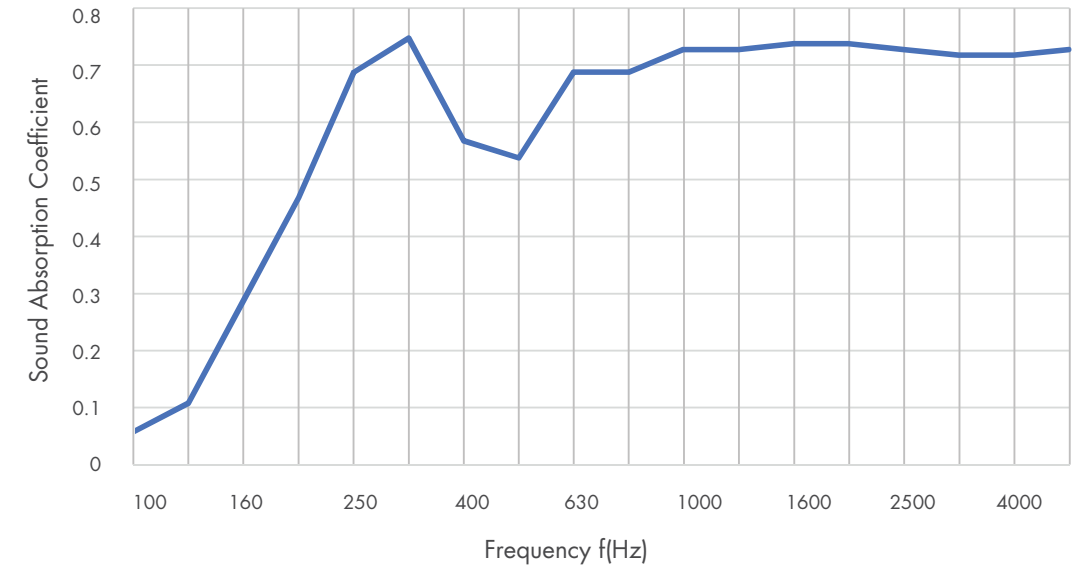

The graph above presents third octave sound absorption coefficients in accordance with ISO 354 measurement of sound absorption in a reverberation room. The table below presents the practical sound absorption coefficients in accordance with ISO 11654. The NRC rating is determined as the arithmetic average of the absorption coefficients measured by one-third octave bands centred on 250 Hz, 500 Hz, 1000 Hz and 2000 Hz and rounded to the nearest 0.05.

Frequency (Hz)	University of Auckland Test Report Number	125	250	500	1000	2000	4000	NRC
3D Tiles S-5.37 140mm	T1316-4	0.15	0.65	0.60	0.70	0.75	0.70	0.65

*These designs don't typically support the AAB application.

PRODUCT SPECIFICATIONS

Product Name	3D Tiles S-5.37
Composition	100% Polyester Fibre (PET)
Tile Dimensions	575mm x 575mm
Tile Tolerance	(+0.5mm) (+0.5mm)
Depth	140mm
Depth Tolerance	(+0.5mm)
Weight	1680 GSM

INSTALLATION

Install as per Autex recommendations. Install instructions are included in each pack or available on the website.

ACOUSTIC PERFORMANCE

3D Tiles S-5.37 are specifically designed to reduce and control reverberated noise (echo) in building interiors.

LIGHT REFLECTANCE VALUES BY COLOUR

Civic	57	Avocado	11
Silver	23	Blush	10
Porcelain	22	Blazing Red	8
Fawn	20	Bark	5
Granny Smith	20	Stately	3
Stonewash	19	Charcoal	3
Brilliant Orange	15	Noir	1
Electric Blue	12		

MEASURED IN ACCORDANCE WITH BS 8493:2008+A1:2010

S-5.46 DESIGN

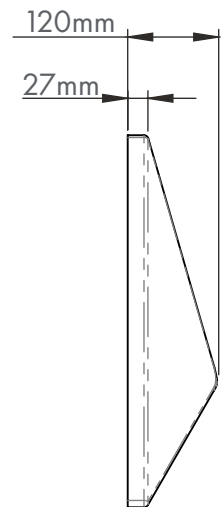
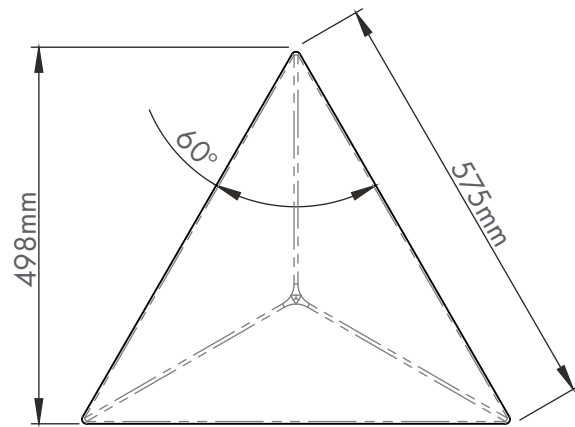

ABSORPTION COEFFICIENT ACCORDING TO ISO 354

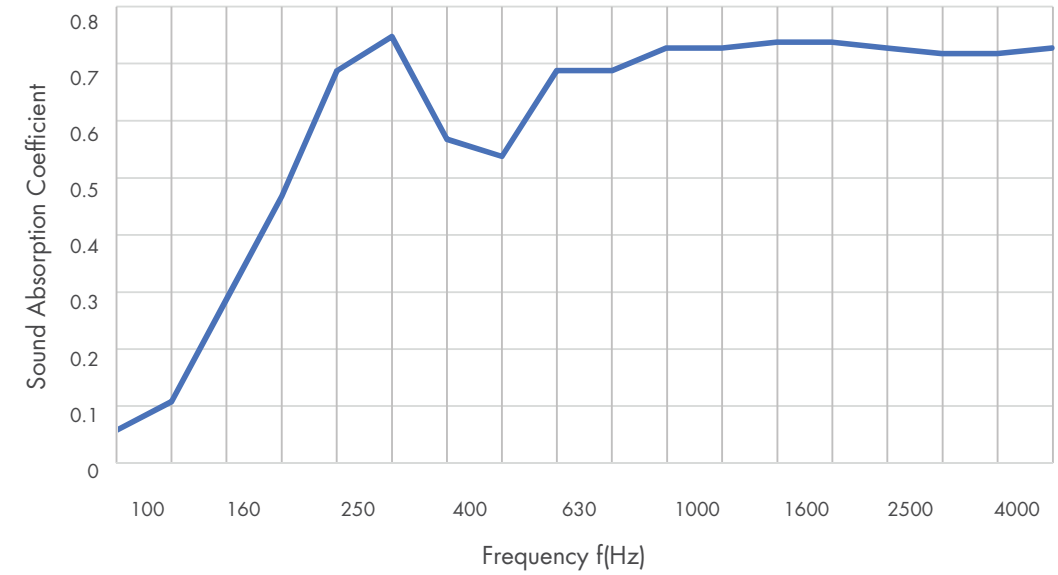

The graph above presents third octave sound absorption coefficients in accordance with ISO 354 measurement of sound absorption in a reverberation room. The table below presents the practical sound absorption coefficients in accordance with ISO 11654. The NRC rating is determined as the arithmetic average of the absorption coefficients measured by one-third octave bands centred on 250 Hz, 500 Hz, 1000 Hz and 2000 Hz and rounded to the nearest 0.05.

Frequency (Hz)	University of Auckland Test Report Number	125	250	500	1000	2000	4000	NRC
3D Tiles S-5.46 120mm	T1316-4	0.15	0.65	0.60	0.70	0.75	0.70	0.65

*These designs don't typically support the AAB application.

PRODUCT SPECIFICATIONS

Product Name	3D Tiles S-5.46
Composition	100% Polyester Fibre (PET)
Tile Dimensions	498mm x 575mm
Tile Tolerance	(+0.5mm) (+0.5mm)
Depth	120mm
Depth Tolerance	(+0.5mm)
Weight	1680 GSM

INSTALLATION

Install as per Autex recommendations. Install instructions are included in each pack or available on the website.

ACOUSTIC PERFORMANCE

3D Tiles S-5.46 are specifically designed to reduce and control reverberated noise (echo) in building interiors.

LIGHT REFLECTANCE VALUES BY COLOUR

Civic	57	Avocado	11
Silver	23	Blush	10
Porcelain	22	Blazing Red	8
Fawn	20	Bark	5
Granny Smith	20	Stately	3
Stonewash	19	Charcoal	3
Brilliant Orange	15	Noir	1
Electric Blue	12		

MEASURED IN ACCORDANCE WITH BS 8493:2008+A1:2010

S-5.50 DESIGN

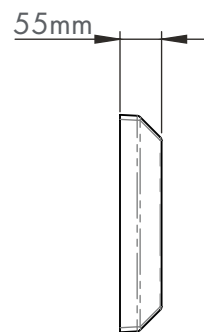
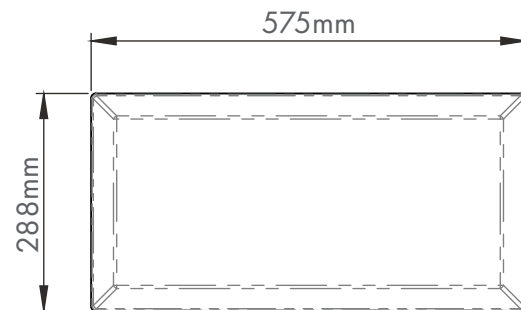

ABSORPTION COEFFICIENT ACCORDING TO ISO 354

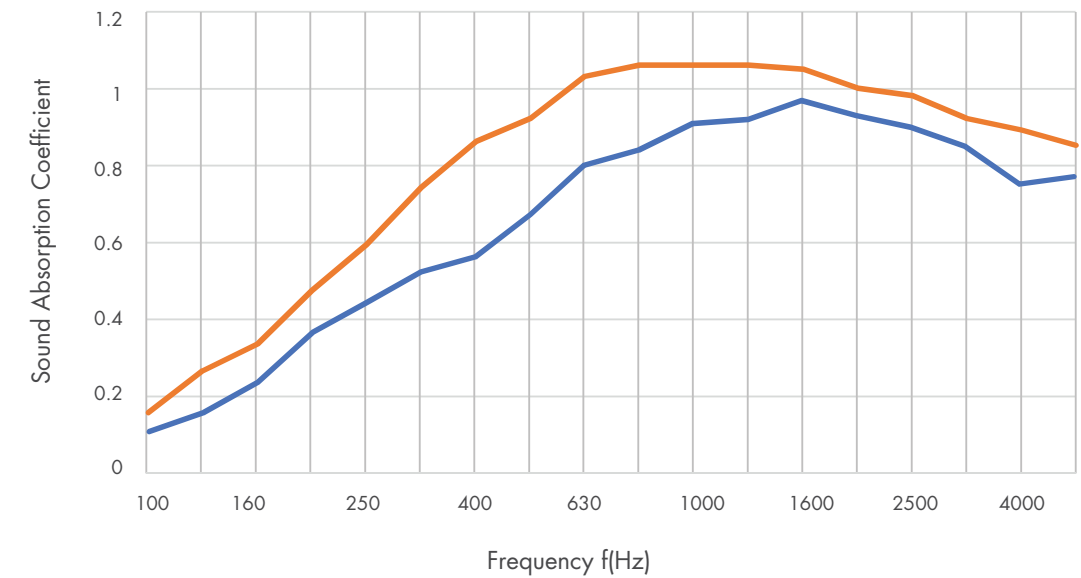

The graph above presents third octave sound absorption coefficients in accordance with ISO 354 measurement of sound absorption in a reverberation room. The table below presents the practical sound absorption coefficients in accordance with ISO 11654. The NRC rating is determined as the arithmetic average of the absorption coefficients measured by one-third octave bands centred on 250 Hz, 500 Hz, 1000 Hz and 2000 Hz and rounded to the nearest 0.05.

Frequency (Hz)	University of Auckland Test Report Number	125	250	500	1000	2000	4000	NRC
3D Tiles without AAB 35-25	T1012-3	0.15	0.45	0.65	0.90	0.90	0.80	0.75
3D Tiles with AAB 35-25	T1012-5	0.25	0.60	0.95	1.05	1.00	0.90	0.90

PRODUCT SPECIFICATIONS

Product Name	3D Tiles S-5.50
Composition	100% Polyester Fibre (PET)
Tile Dimensions	288mm x 575mm
Tile Tolerance	(+0.5mm) (+0.5mm)
Depth	55mm
Depth Tolerance	(+0.5mm)
Weight	1680 GSM

INSTALLATION

Install as per Autex recommendations. Install instructions are included in each pack or available on the website.

ACOUSTIC PERFORMANCE

3D Tiles S-5.50 are specifically designed to reduce and control reverberated noise (echo) in building interiors. To increase acoustic performance, use Autex AAB 35-25 polyester acoustic insulation as an infill. Refer to www.autexindustries.com/greenstuf/greenstuf-aab.

LIGHT REFLECTANCE VALUES BY COLOUR

Civic	57	Avocado	11
Silver	23	Blush	10
Porcelain	22	Blazing Red	8
Fawn	20	Bark	5
Granny Smith	20	Stately	3
Stonewash	19	Charcoal	3
Brilliant Orange	15	Noir	1
Electric Blue	12		

MEASURED IN ACCORDANCE WITH BS 8493:2008+A1:2010

S-5.53 DESIGN

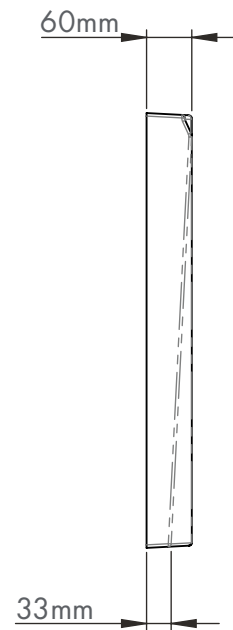
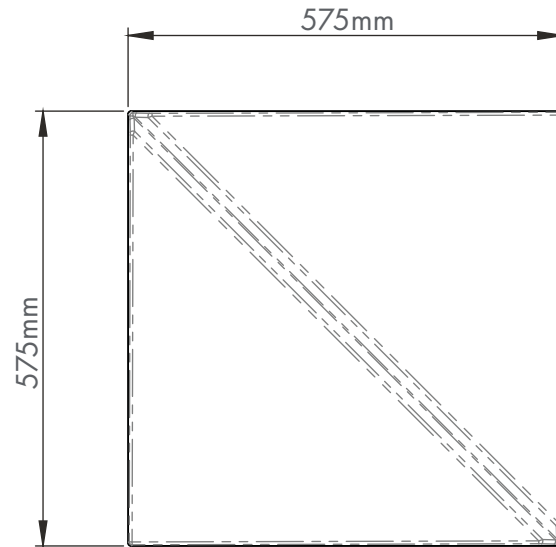

ABSORPTION COEFFICIENT ACCORDING TO ISO 354

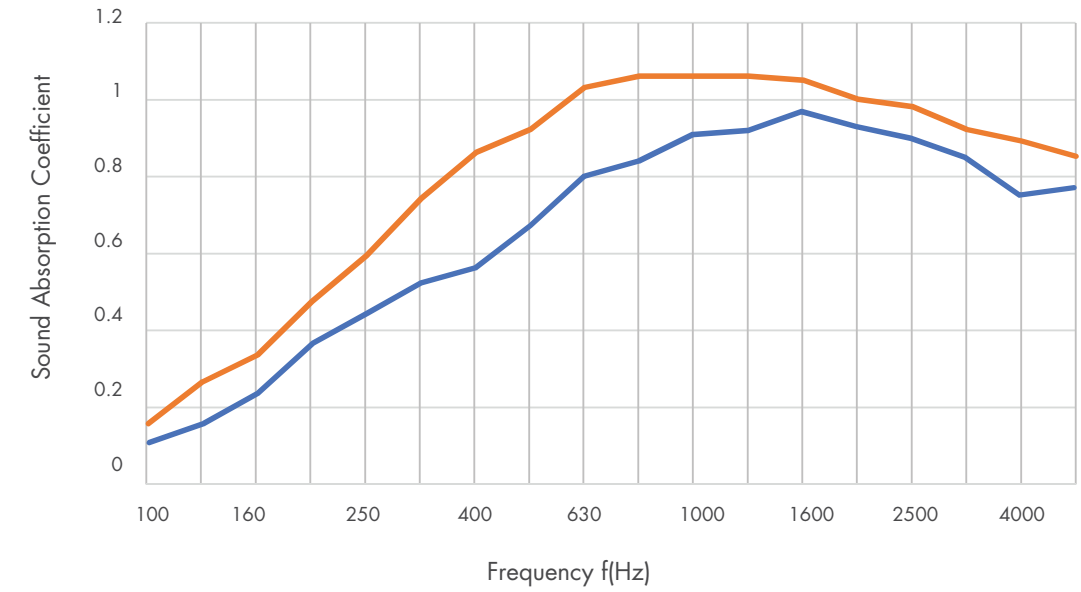

The graph above presents third octave sound absorption coefficients in accordance with ISO 354 measurement of sound absorption in a reverberation room. The table below presents the practical sound absorption coefficients in accordance with ISO 11654. The NRC rating is determined as the arithmetic average of the absorption coefficients measured by one-third octave bands centred on 250 Hz, 500 Hz, 1000 Hz and 2000 Hz and rounded to the nearest 0.05.

Frequency (Hz)	University of Auckland Test Report Number	125	250	500	1000	2000	4000	NRC
3D Tiles without AAB 35-25	T1012-3	0.15	0.45	0.65	0.90	0.90	0.80	0.75
3D Tiles with AAB 35-25	T1012-5	0.25	0.60	0.95	1.05	1.00	0.90	0.90

PRODUCT SPECIFICATIONS

Product Name	3D Tiles S-5.53
Composition	100% Polyester Fibre (PET)
Tile Dimensions	575mm x 575mm
Tile Tolerance	(+0.5mm) (+0.5mm)
Depth	60mm
Depth Tolerance	(+0.5mm)
Weight	1680 GSM

INSTALLATION

Install as per Autex recommendations. Install instructions are included in each pack or available on the website.

ACOUSTIC PERFORMANCE

3D Tiles S-5.53 are specifically designed to reduce and control reverberated noise (echo) in building interiors. To increase acoustic performance, use Autex AAB 35-25 polyester acoustic insulation as an infill. Refer to www.autexindustries.com/greenstuf/greenstufaab.

LIGHT REFLECTANCE VALUES BY COLOUR

Civic	57	Avocado	11
Silver	23	Blush	10
Porcelain	22	Blazing Red	8
Fawn	20	Bark	5
Granny Smith	20	Stately	3
Stonewash	19	Charcoal	3
Brilliant Orange	15	Noir	1
Electric Blue	12		

MEASURED IN ACCORDANCE WITH BS 8493:2008+A1:2010

FIRE RATINGS

3D Tiles is a value-added product made from Autex Workstation as the base material. Workstation has been evaluated using the following test methods:

ISO 9705: 1993

Classification: Group 1-S
Smoke Production Rate: <5.0m²/s
As required by NZBC C/VM2

AS ISO 9705 - 2003

Classification: Group 1
(SMOGRARC): <100m²/s²
Assessed using methodology AS ISO 9705:2003 in accordance with AS 5637.1:2015 as required by BCA Specification C1.10-4

FAR 4055

EN13501-1:2007+A1:2009 (6mm Workstation)

B - s1, d2

Report WF 336913 dated 19th March 2014

ASTM E84 - 14 (12mm Workstation)

Class A, FS:0 - SD:10
Report RJ3297-10 dated 13th June 2014

VOC EMISSIONS

Autex polyester has been tested for chemical emissions in accordance with ASTM D5116 and is considered as a low VOC product. VOC concentration: 0.009 mg/m³ (7 days).

WATER VAPOUR SORPTION

ASTM C1104 / C1104M-13a
Test conditions: 49°C, 95%RH
Water vapour absorbed and adsorbed after 4 days: 0.4% by weight.

MICROBIAL RESISTANCE

ASTM G21-15
Growth Rating: 0 (No growth)
3D Tiles do not promote the growth of moulds and mildew.

COLOUR FASTNESS TO LIGHT

3D Tiles are suitable for indoor use only. Lightfastness is dependent on use and exposure. 3D Tiles have been evaluated to the following standard:
ISO 105-B02:2014
Rating: 6 (Highest = 7)

COLOUR FASTNESS TO RUBBING

ISO 105-X12:2016
Dry Rating: 4-5 (Highest = 5)
Wet Rating: 4-5 (Highest = 5)

PATTERN REPEAT

Non-woven. No pattern repeat, but the product has a directional grain. Product may vary from samples and batch to batch due to fibre blending and lay-up, which is an inherent feature of this product.

FABRIC CARE

Blot spills from fabric quickly. Wipe with a damp cloth. Avoid rubbing and using excessive amounts of water as this will affect the finish. Use carpet or upholstery shampoo as directed. Blot with a clean, dry cloth after each application of the solution.

Custom printed Workstation requires the services of a specialist cleaning company. Refer to the 3D Tiles Care and Maintenance Guide for more information.

ENVIRONMENTAL

Autex is committed to best practice through our ISO 9001 and ISO 14001 certified Quality and Environmental Management Systems.

Autex 3D Tiles contain a minimum of 55% previously recycled polyester fibre (from PET bottle-flake). Off-cuts and manufacturing waste are re-used or recycled wherever possible.

Autex 3D Tiles are manufactured from 100% polyester fibres and do not contain formaldehyde binders. Autex polyester fibres support safer indoor air quality and will not become a potential airborne pollutant.

SERVICE

For further information about 3D Tiles, Workstation or any other Autex product, please contact your Autex account manager or visit our website.

3D TILES
DESIGN: S-5.46
COLOUR: ELECTRIC
BLUE, GRANNY SMITH,
MYST AND SILVER

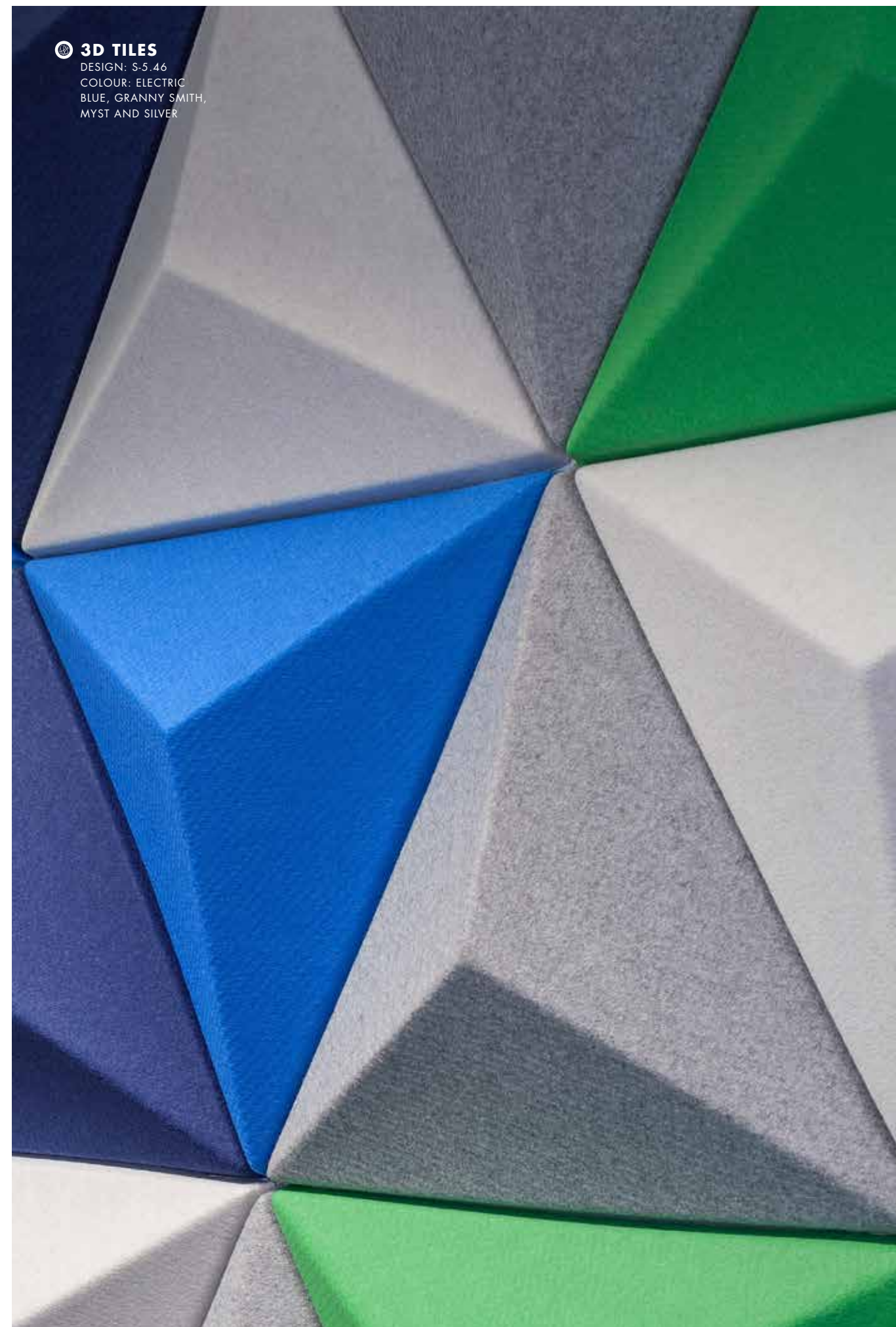

3D TILES
DESIGN: CUSTOM
COLOUR: CHARCOAL,
SILVER AND STATELY

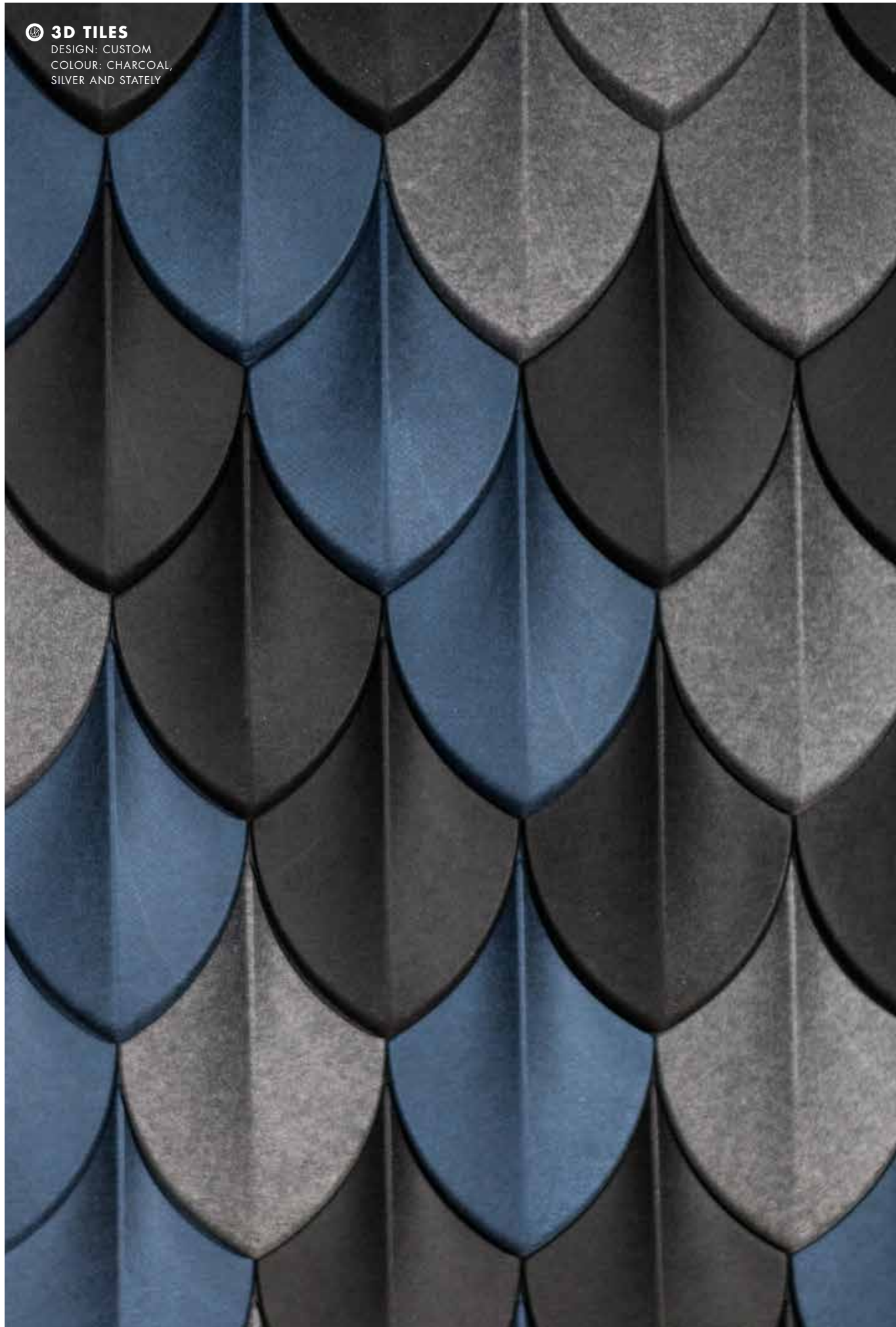

3D TILES COLOUR OPTIONS



MOQ's apply to some colours, custom colour available on request.
To find out more, or to order a sample, please contact your account
manager or visit our website.



CARING FOR THE ENVIRONMENT

3D Tiles are manufactured using 100% polyester fibre and contain a minimum of 55% previously recycled fibre (from PET plastics). Our products are designed to be recycled at the end of their life too.

We use Life Cycle Analysis (LCA) to understand the environmental impacts of our products and set targets to reduce these. All our products have been verified as low VOC and are free from chemical binders, making them great for indoor environmental quality (IEQ). We have continual improvement programmes in which we implement a range of initiatives to mitigate the environmental 'hotspots' that we have identified. Our products are GreenRate Level A, LCARate Gold and PHD level platinum certified.

3D Tiles are made from Workstation which is DeclareSM certified to be Red List Free and can be used in Living Building Challenge projects. Autex has a high functioning Environmental Management System (ISO 14001) to enhance our environmental performance and contribute to sustainable development.



Declare.



Autex Industries Ltd

702-718 Rosebank Rd,
Private Bag 19988,
Avondale 1746, Auckland,
New Zealand
Freephone **0800 428 839**
Phone **+64 9 828 9179**
Fax **+64 9 828 5810**

www.autex.co.nz

Autex Australia Pty Ltd

166 Bamfield Road,
PO Box 5099,
West Heidelberg, Melbourne,
VIC 3081, Australia
Freephone **1800 678 160**
Phone **+61 3 9457 6700**
Fax **+61 3 9457 1020**

www.autex.com.au

Autex Acoustics Ltd

Unit J4, Lowfields Way,
Lowfields Business Park,
Elland, West Yorkshire,
Hx5 9Da,
United Kingdom
Phone **+44 0 1422 418899**

www.autexacoustics.co.uk

Autex Acoustics LLC

19350 Van Ness Avenue
Torrance, CA 90501
United States of America
Phone **+1 310 490 1591**

www.autexacoustics.com